

# JOINT PUBLIC NOTICE

September 17, 2018

United States Army  
Corps of Engineers  
New Orleans District  
Regulatory Branch  
7400 Leake Avenue  
New Orleans, LA 70118-3651

State of Louisiana  
Department of Environmental Quality  
Post Office Box 4313  
Baton Rouge, La. 70821-4313  
Attn: Water Quality Certifications

(504) 862-2548/ FAX (504) 862-2574  
Project Manager  
Johnny Duplantis  
Permit Application Number  
MVN-2016-00678-WPP

(225) 219-3225/FAX (225) 325-8125  
Project Manager  
Elizabeth Hill  
WQC Application Number  
WQC # 180911-01

Interested parties are hereby notified that a permit application has been received by the New Orleans District of the U.S. Army Corps of Engineers pursuant to: [X] Section 10 of the Rivers and Harbors Act of March 3, 1899 (30 Stat. 1151; 33 USC 403); and/or [X] Section 404 of the Clean Water Act (86 Stat. 816; 33 USC 1344).

Application has also been made to the Louisiana Department of Environmental Quality, for a Water Quality Certification (WQC) in accordance with statutory authority contained in Louisiana Revised Statutes of 1950, Title 30, Chapter 11, Part IV, Section 2074 A(3) and provisions of Section 401 of the Clean Water Act (P.L.95-17).

## **CALCASIEU SALINITY CONTROL MEASURES PROJECT IN CALCASIEU PARISH**

**NAME OF APPLICANT:** Louisiana Coastal Protection and Restoration Authority, Post Office Box 44027, Baton Rouge, Louisiana, 70804-4027.

**LOCATION:** Project located at approximately Latitude 29.85861, Longitude -93.34694, on the Calcasieu Ship Channel, in the community of Lake Charles, within Calcasieu Parish, Louisiana. The Project is located within the Calcasieu Watershed, Hydrologic Unit 08080206.

**DESCRIPTION:** The applicant proposes construction of structures designed to control saltwater entering Calcasieu Lake through the Calcasieu Ship Channel. Structures would control salinity spikes, provide storm surge benefits, and would be constructed in a manner that would allow for the continued functioning, improvement and viability of the Calcasieu Ship Channel and the Port of Lake Charles. The purpose of the proposed project is to manage the introduction of saline water from the Calcasieu Ship Channel into adjacent water bodies thereby reducing the rate of wetland loss in the project area and surrounding wetlands. To achieve, in part, the goals in the 2012 Louisiana State Master Plan, the proposed project is needed to address modifications to hydrology that have caused an increase in salinity within the project area, resulting in loss of wetlands. This project, as proposed, should achieve the following: (1) manage salinity levels in Calcasieu Lake and adjacent marshes to maintain marsh productivity and avoid marsh collapse; (2) minimize the economic impact to the navigation industry caused by potential delays in travel times resulting from any structures or modifications to the ship channel and avoid actions that cause safety issues for vessel operation; (3) achieve salinity management with minimal changes to the magnitude, frequency, duration, or extent of flood conditions in the project area. The project study area has undergone substantial land loss since 1932. The present-day Calcasieu Ship Channel cross section is more than 40 times larger than

when it was first dredged for navigation in the late 1800s. This change has affected hydrology by: channeling saltwater inland into a historically low-salinity estuary; reducing freshwater residence time when the tide ebbs; and, increasing tidal amplitude through the broader waterway. Approximately 866,160 cubic yards (cy) of material would be excavated and redeposited onsite, approximately 97,791 cy of material would be excavated and hauled offsite, and approximately 1,219,246 cy of rock material would be deposited onsite for project construction. The project would potentially affect 56,244 acres of wetlands and/or waterbottoms. Approximately 6 acres of vegetated wetlands between the water's edge and tie-in locations of adjacent spoil banks would be permanently impacted by project construction. Additionally, the project would provide 30 acres of newly constructed artificial reef and, over the life of the project, an estimated 12,000 acres of marsh would be protection and sustained.

The comment period for the Department of the Army Permit and the Louisiana Department of Environmental Quality WQC will close **20 days** from the date of this joint public notice. Written comments, including suggestions for modifications or objections to the proposed work, stating reasons thereof, are being solicited from anyone having interest in this permit and/or this WQC request and must be mailed so as to be received before or by the last day of the comment period. Letters concerning the Corps of Engineers permit application must reference the applicant's name and the Permit Application Number, and be mailed to the Corps of Engineers at the address above, **ATTENTION: REGULATORY BRANCH**. Similar letters concerning the Water Quality Certification must reference the applicant's name and the WQC Application number and be mailed to the Louisiana Department of Environmental Quality at the address above.

The application for this proposed project is on file with the Louisiana Department of Environmental Quality and may be examined during weekdays between 8:00 a.m. and 5:00 p.m. Copies may be obtained upon payment of costs of reproduction.

### **Corps of Engineers Permit Criteria**

The decision whether to issue a permit will be based on an evaluation of the probable impacts, including cumulative impacts of the proposed activity on the public interest. That decision will reflect the national concern for both protection and utilization of important resources. The benefit which reasonably may be expected to accrue from the proposal must be balanced against its reasonably foreseeable detriments. All factors which may be relevant to the proposal will be considered including the cumulative effects thereof; among those are conservation, economics, aesthetics, general environmental concerns, wetlands, historic properties, fish and wildlife values, flood hazards, floodplain values, land use, navigation, shoreline erosion and accretion, recreation, water supply and conservation, water quality, energy needs, safety, food and fiber production, mineral needs, considerations of property ownership and, in general, the needs and welfare of the people.

The U.S. Army Corps of Engineers is soliciting comments from the public, federal, state, and local agencies and officials, Indian Tribes, and other interested parties in order to consider and evaluate the impacts of this proposed activity. Any comments received will be considered by the U.S. Army Corps of Engineers to determine whether to make, modify, condition, or deny a permit for this proposal. To make this decision, comments are used to assess impacts on endangered species, historic properties, water quality, general environmental effects, and other public interest factors listed above. Comments are used in the preparation of an Environmental Assessment and/or an Environmental Impact Statement pursuant to the National Environmental Policy Act. Comments are also used to determine the need for a public hearing and to determine the overall public interest of the proposed activity.

The New Orleans District is unaware of properties listed on the National Register of Historic Places near the proposed work. The possibility exists that the proposed work may damage or destroy presently unknown archeological, scientific, pre-historical, historical sites, or data. Copies of this notice are being sent to the State Archeologist and the State Historic Preservation Officer.

Our initial finding is that the proposed work would neither affect any species listed as endangered by the U.S. Departments of Interior or Commerce, nor affect any habitat designated as critical to the survival and recovery of any endangered species. Based on the South Louisiana Standard Local Operating Procedure for Endangered Species (SLOPES), as signed on October 22, 2014, between the U.S. Army Corps of Engineers, New Orleans and the U.S. Fish and Wildlife Service, it has been determined that the project is located in waters known to be utilized by the Western Indian Manatee and determined that the activity is not likely to adversely affect this species. If this permit is issued, the permittee will be required to follow the SLOPES Manatee conditions.

This notice initiates the Essential Fish Habitat (EFH) consultation requirements of the Magnuson-Stevens Fishery Conservation and Management Act. The applicant's proposal would result in the destruction or alteration of 56,244 acre(s) of EFH utilized by various life stages of red drum and penaeid shrimp. Our initial determination is that the proposed action would not have a substantial adverse impact on EFH or federally managed fisheries in the Gulf of Mexico. Our final determination relative to project impacts and the need for mitigation measures is subject to review by and coordination with the National Marine Fisheries Service.

If the proposed work involves deposits of dredged or fill material into navigable waters, the evaluation of the probable impacts will include the application of guidelines established by the Administrator of the Environmental Protection Agency. Also, a certification that the proposed activity will not violate applicable water quality standards will be required from the Department of Environmental Quality, before a permit is issued.

Any person may request, in writing, within the comment period specified in this notice, that a public hearing be held to consider this application. Requests for public hearings shall state, with particularity, the reasons for holding a public hearing.

The applicant has certified that the proposed activity described in the application complies with and will be conducted in a manner that is consistent with the Louisiana Coastal Resources Program. The Department of the Army permit will not be issued unless the applicant received approval or a waiver of the Coastal Use Permit by the Department of Natural Resources.

You are requested to communicate the information contained in this notice to any other parties whom you deem likely to have interest in the matter.

Darrell S. Barbara  
Chief, Western Evaluation Section  
Regulatory Branch

Enclosures

INDEX TO SHEETS

SHEET NO.	DESCRIPTION
1	TITLE SHEET
2	GENERAL NOTES
3	ACCESS PLAN
4	CROSS SECTIONS A - D
5	EAST PASS
6	WEST PASS
7	CROSS SECTIONS E - F
8	JOE'S CUT
9	LAKE WALL KEY PLAN
10	LAKE WALL 1 OF 3
11	LAKE WALL 2 OF 3
12	LAKE WALL 3 OF 3
13	NINE MILE CUT
14	SILL DETAIL 1
15	SILL DETAIL 2
16	FISH PASSAGE
17	TIE-IN DETAIL 1
18	TIE-IN DETAIL 2
19	TEMPORARY ACCESS CHANNEL

**STATE OF LOUISIANA  
COASTAL PROTECTION AND RESTORATION AUTHORITY**

**CALCASIEU SHIP CHANNEL SALINITY  
CONTROL MEASURES**

CS-65  
CAMERON PARISH  
T14S - R10W, T13S - R10W  
(NAD 83: LAT/LONG)

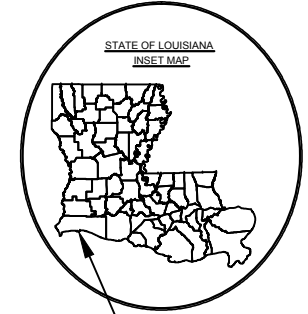

PROJECT LOCATION

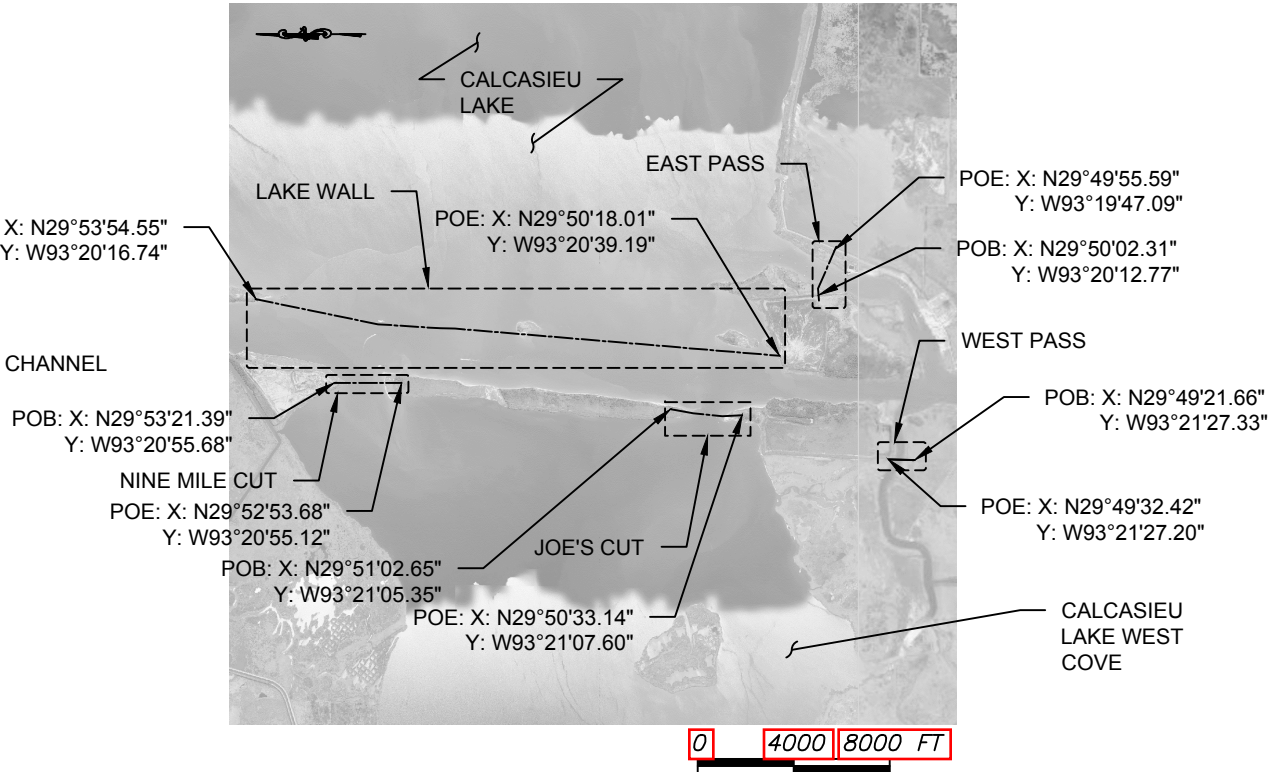



PRELIMINARY - FOR PERMIT PURPOSES ONLY

APPLICATION BY: COASTAL PROTECTION AND RESTORATION AUTHORITY 150 TERRACE STREET BATON ROUGE, LA 70802	COASTAL PROTECTION AND RESTORATION AUTHORITY 150 TERRACE STREET BATON ROUGE, LOUISIANA 70802	CALCASIEU SALINITY CONTROL MEASURES	TITLE SHEET
		STATE PROJECT NUMBER: CS-65	DATE: 20-APR-2018
DRAWN BY: SPF	DESIGNED BY: LRM	APPROVED BY: BR	FEDERAL PROJECT NUMBER: SHEET 1 OF 19

**ACRONYMS AND ABBREVIATIONS:**

CDF CONFINED DISPOSAL FACILITY  
 CL, € CENTER LINE  
 CSC CALCASIEU SHIP CHANNEL  
 D DIAMETER  
 EG EXISTING GRADE  
 EL ELEVATION  
 GIWW GULF INTRACOASTAL WATERWAY  
 GPS GLOBAL POSITIONING SYSTEM  
 LOC LOCATIONS  
 MHW MEAN HIGH WATER  
 MLG MEAN LOW GULF  
 MLW MEAN LOW WATER  
 NTS NOT TO SCALE  
 POB POINT OF BEGINNING  
 POE POINT OF ENDING  
 R RADIUS  
 REF REFERENCE  
 REQ'D REQUIRED  
 SIM SIMILAR  
 SLL STRUCTURE LIMIT LINE  
 STA STATION  
 SYM SYMMETRICAL  
 TYP TYPICAL  
 UON UNLESS OTHERWISE NOTED  
 VERT VERTICAL  
 W□ WITH

**LEGEND:**

-  ACCESS CHANNEL
-  ACCESS CORRIDOR
-  TEMPORARY SPOIL PLACEMENT AREA

**GENERAL NOTES:**

1. BACKGROUND IMAGERY BASED ON NAIP (2015).
2. PLANS ARE BASED ON SURVEY CONDUCTED BY LONNIE HARPER □ ASSOCIATES IN 2016 AND 2017, UNLESS STATED OTHERWISE. THE HORIZONTAL DATUM IS NAD 83, LOUISIANA SOUTH □ ONE-STATE PLANE COORDINATE SYSTEM. THE VERTICAL DATUM IS NAVD88, GEOID 12B. THE UNITS ARE U.S. SURVEY FEET.
3. THERE IS NO UPLAND ACCESS TO THE PROJECT SITE. CONTRACTOR SHALL ACCESS THE PROJECT SITE FROM A NAVIGABLE WATER BODY SUCH AS THE CALCASIEU SHIP CHANNEL.
4. TEMPORARY ACCESS FLOTATION CHANNEL DREDGING MAY BE REQUIRED TO ACCESS THE PROJECT SITE. ALL DREDGED MATERIAL MAY BE PLACED INTO THE TEMPORARY SPOIL PLACEMENT AREAS SHOWN. THE TEMPORARY SPOILS SHALL BE BACKFILLED INTO THE TEMPORARY ACCESS CHANNEL AT THE COMPLETION OF THE PROJECT.
5. PERMANENT NAVIGATION AIDS TO BE LOCATED AND MARKED LIGHTED IN ACCORDANCE WITH U.S. COAST GUARD REGULATIONS.
6. AS-BUILT DRAWINGS AND/OR PLATS SHALL HAVE WRITTEN ON THEM THE DATE OF COMPLETION OF SAID ACTIVITIES AND SHALL BE SUBMITTED TO THE LOUISIANA DEPARTMENT OF NATURAL RESOURCES, OFFICE OF COASTAL MANAGEMENT, P.O. BOX 44487, BATON ROUGE, LA 70804-4487 WITHIN 30 DAYS FOLLOWING PROJECT COMPLETION.
7. IN ORDER TO ENSURE THE SAFETY OF ALL PARTIES, THE PERMITTEE SHALL CONTACT THE LOUISIANA ONE CALL SYSTEM (1-800-272-3020) A MINIMUM OF 48 HOURS PRIOR TO THE COMMENCEMENT OF ANY EXCAVATION (DIGGING, DREDGING, JETTING, ETC.) OR DEMOLITION ACTIVITY.

OVERALL QUANTITY SUMMARY	
TYPE	QUANTITY
WALL LENGTH	28,701 LF
WALL AREA	56.04 ACRES
ROCK VOLUME	1,219,246 CY
PERMANENT DREDGE AREA	29.31 ACRES
PERMANENT DREDGE VOLUME	95,791 CY
TEMPORARY ACCESS FLOTATION DREDGING AREA	101.61 ACRES
TEMPORARY ACCESS FLOTATION DREDGING VOLUME	886,160 CY
TEMPORARY SPOIL PLACEMENT AREA	130.42 ACRES
TEMPORARY ACCESS CORRIDOR AREA	11.61 ACRES

OVERALL ESTIMATED IMPACT	
TYPE	QUANTITY
PERMANENT IMPACTED VEGETATED WETLANDS	5.29 ACRES
TEMPORARY IMPACTED VEGETATED WETLANDS	10.96 ACRES
PERMANENT IMPACTED SUBMERGED BOTTOM	50.19 ACRES
TEMPORARY IMPACTED SUBMERGED BOTTOM	232.03 ACRES

OVERALL ESTIMATED BENEFITS	
TYPE	QUANTITY
DIRECT BENEFITS	
50-YEAR PROTECTION	

PRELIMINARY - FOR PERMIT PURPOSES ONLY

APPLICATION BY: COASTAL PROTECTION AND RESTORATION AUTHORITY 150 TERRACE STREET BATON ROUGE, LA 70802	 COASTAL PROTECTION AND RESTORATION AUTHORITY 150 TERRACE STREET BATON ROUGE, LOUISIANA 70802	CALCASIEU SALINITY CONTROL MEASURES	GENERAL NOTES
		STATE PROJECT NUMBER: CS-65	DATE: 20-APR-2018
DRAWN BY: SPF	DESIGNED BY: LRM	APPROVED BY: BR	FEDERAL PROJECT NUMBER: SHEET 2 OF 19



Source: 2017 NAIP

<p>APPLICATION BY:          TETRA TECH          748 MAIN STREET, SUITE B          BATON ROUGE, LA 70802</p>		<p><b>COASTAL PROTECTION          AND RESTORATION          AUTHORITY</b>          150 TERRACE STREET          BATON ROUGE, LOUISIANA 70802</p>	<p>CALCASIEU SALINITY          CONTROL MEASURES</p>	<p>ACCESS PLAN</p>
<p>DRAWN BY: HMC</p>	<p>DESIGNED BY: BR</p>	<p>APPROVED BY: SDG</p>	<p>STATE PROJECT NUMBER: CS-65          FEDERAL PROJECT NUMBER:</p>	<p>DATE:          SHEET 3 OF 18</p>

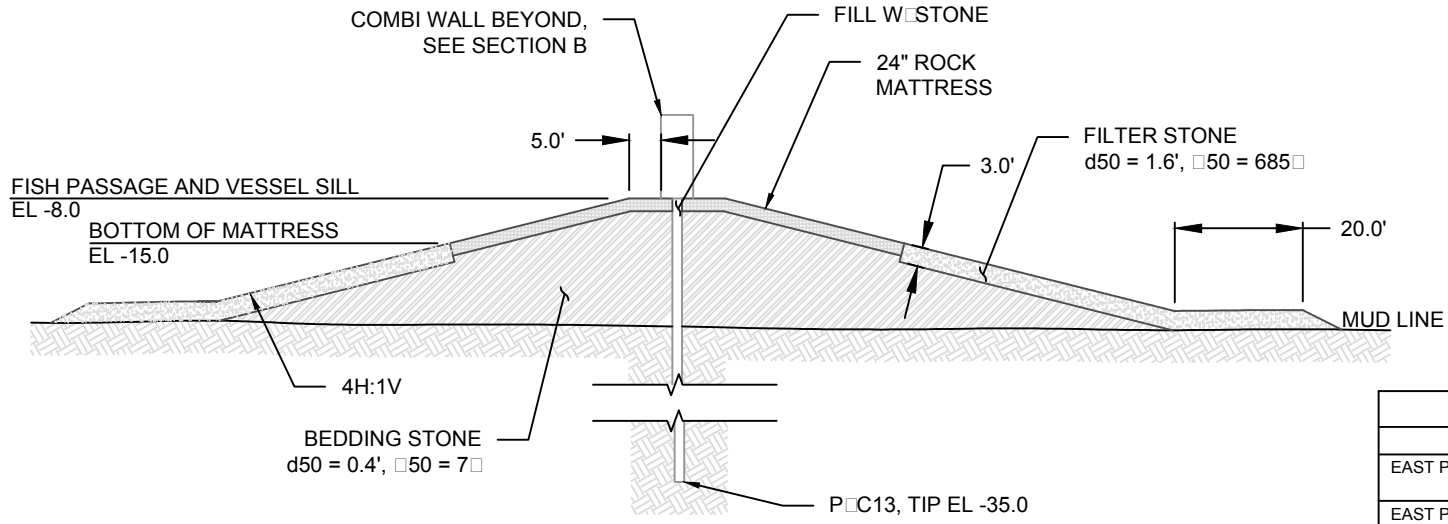

**(A) SILL SECTION**  
SCALE: 1"=30'

- NOTES:**
1. ALL SECTIONS SYM ABOUT CL
  2. PAINT TOP 10 FEET OF PILES.
  3. REFER TO TABLE FOR PILE SECTION AND TIP ELEVATION.

PILE SECTIONS	
FEATURE	SECTION
EAST PASS REACH B, MUD LINE EL -23.0 TO -28.0	60" <math>\square</math>0.875" PIPE <math>\square</math>TIP EL -85.0, P<math>\square</math>C 13 <math>\square</math>TIP EL -35.0
EAST PASS REACH B, MUD LINE EL -8.0 TO -23.0	48" <math>\square</math>0.75" PIPE <math>\square</math>TIP EL -65.0, P<math>\square</math>C 13 <math>\square</math>TIP EL -35.0
EAST PASS, REACH C <math>\square</math> D	P<math>\square</math>C 26, TIP EL -35.0
EAST PASS REACH B, MUD LINE EL -23.0 TO -28.0	48" <math>\square</math>0.50" PIPE <math>\square</math>TIP EL -65.0, P<math>\square</math>C 13 <math>\square</math>TIP EL -35.0
EAST PASS REACH B, MUD LINE EL -8.0 TO -23.0	42" <math>\square</math>0.50" PIPE <math>\square</math>TIP EL -55.0, P<math>\square</math>C 13 <math>\square</math>TIP EL -35.0
WEST PASS, REACH C <math>\square</math> D	P<math>\square</math>C 26, TIP EL -35.0
JOE'S CUT, REACH B	48" <math>\square</math>0.50" PIPE <math>\square</math>TIP EL -60.0, P<math>\square</math>C 13 <math>\square</math>TIP EL -35.0

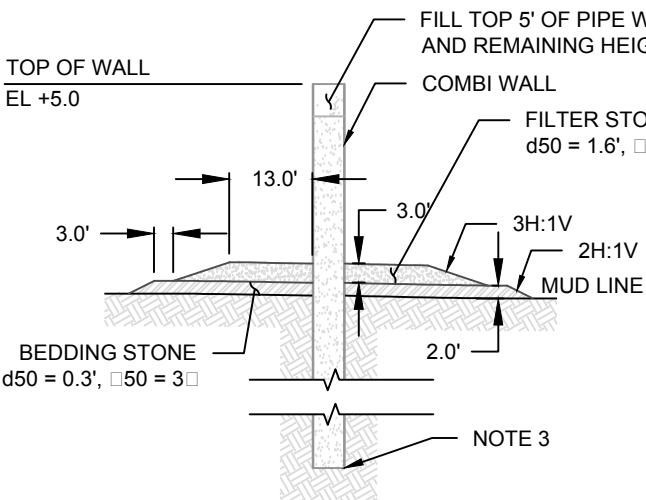

**(B) SECTION**  
SCALE: 1"=30'

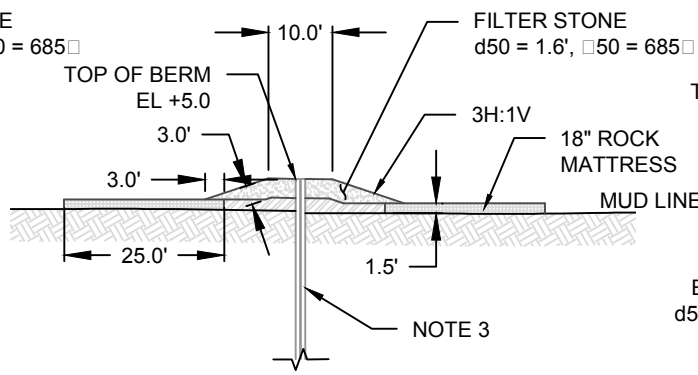

**(C) SECTION**  
SCALE: 1"=30'

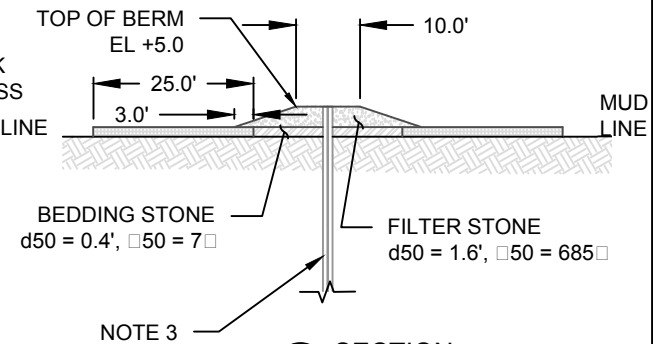

**(D) SECTION**  
SCALE: 1"=30'

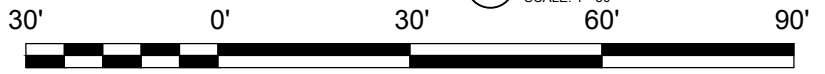

APPLICATION BY: COASTAL PROTECTION AND RESTORATION AUTHORITY 150 TERRACE STREET BATON ROUGE, LA 70802	<b>COASTAL PROTECTION AND RESTORATION AUTHORITY</b> 150 TERRACE STREET BATON ROUGE, LOUISIANA 70802	CALCASIEU SALINITY CONTROL MEASURES	CROSS SECTIONS A - D	
DRAWN BY: SPF		DESIGNED BY: LRM	APPROVED BY: BR	STATE PROJECT NUMBER: CS-65
		FEDERAL PROJECT NUMBER:	SHEET 4 OF 19	

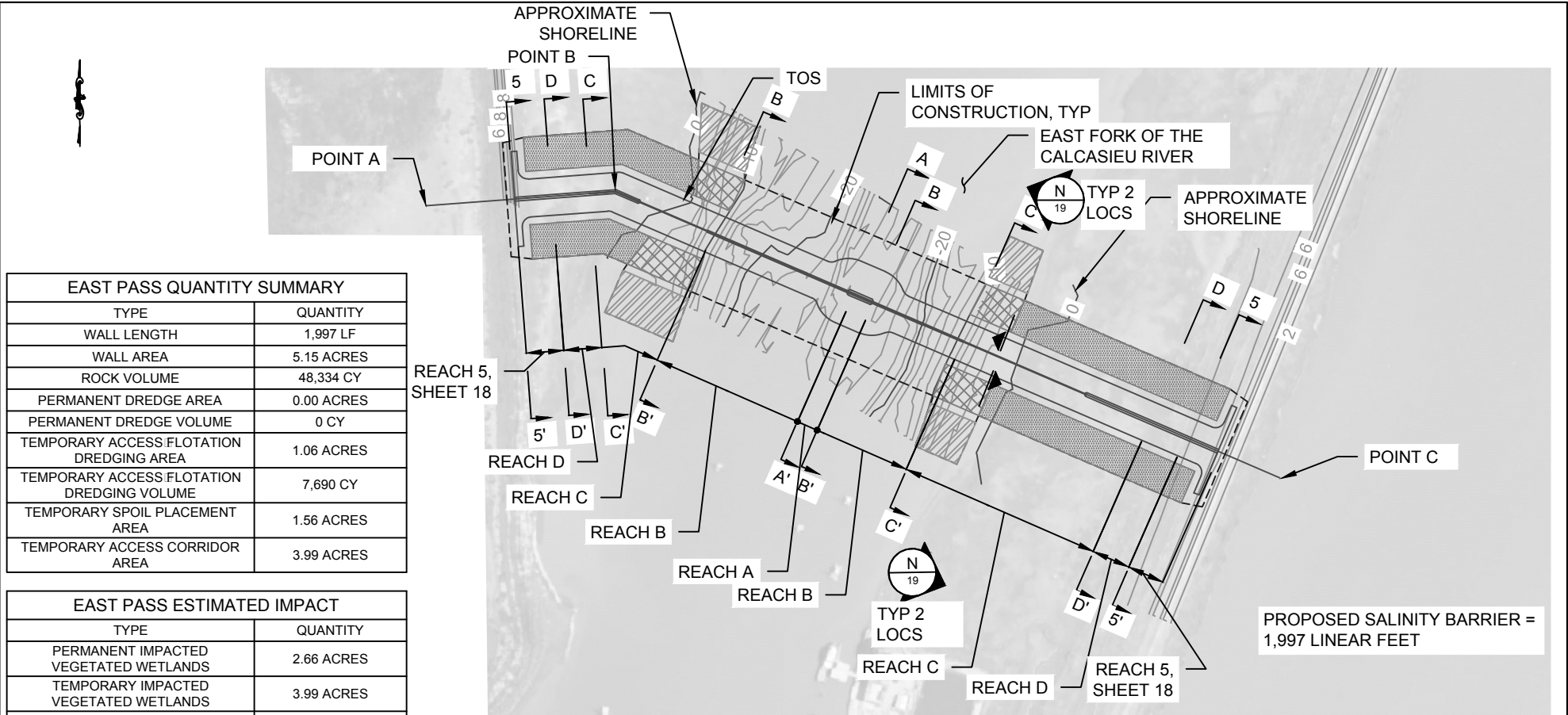

EAST PASS QUANTITY SUMMARY	
TYPE	QUANTITY
WALL LENGTH	1,997 LF
WALL AREA	5.15 ACRES
ROCK VOLUME	48,334 CY
PERMANENT DREDGE AREA	0.00 ACRES
PERMANENT DREDGE VOLUME	0 CY
TEMPORARY ACCESS FLOTATION DREDGING AREA	1.06 ACRES
TEMPORARY ACCESS FLOTATION DREDGING VOLUME	7,690 CY
TEMPORARY SPOIL PLACEMENT AREA	1.56 ACRES
TEMPORARY ACCESS CORRIDOR AREA	3.99 ACRES

EAST PASS ESTIMATED IMPACT	
TYPE	QUANTITY
PERMANENT IMPACTED VEGETATED WETLANDS	2.66 ACRES
TEMPORARY IMPACTED VEGETATED WETLANDS	3.99 ACRES
PERMANENT IMPACTED SUBMERGED BOTTOM	2.49 ACRES
TEMPORARY IMPACTED SUBMERGED BOTTOM	2.61 ACRES

ALIGNMENT TABLE		
P	LATITUDE	LONGITUDE
A	N29° 50' 02.31"	W93° 20' 12.77"
B	N29° 50' 02.77"	W93° 20' 07.12"
C	N29° 49' 55.62"	W93° 19' 47.16"

MHW= +0.78 FT  
 MLW= -0.08 FT  
 (NAVD 88)

**EAST PASS**  
 SCALE: 1" = 400'

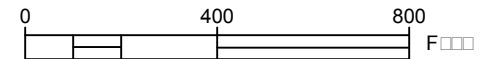

APPLICATION BY:  
 COASTAL PROTECTION AND RESTORATION AUTHORITY  
 150 TERRACE STREET  
 BATON ROUGE, LA 70802

DRAWN BY: VR

DESIGNED BY: LRM

**COASTAL PROTECTION AND RESTORATION AUTHORITY**  
 150 TERRACE STREET  
 BATON ROUGE, LOUISIANA 70802

APPROVED BY: BR

CALCASIEU SALINITY CONTROL MEASURES

STATE PROJECT NUMBER: CS-65

FEDERAL PROJECT NUMBER:

EAST PASS

DATE: 20-APR-2018

SHEET 5 OF 19



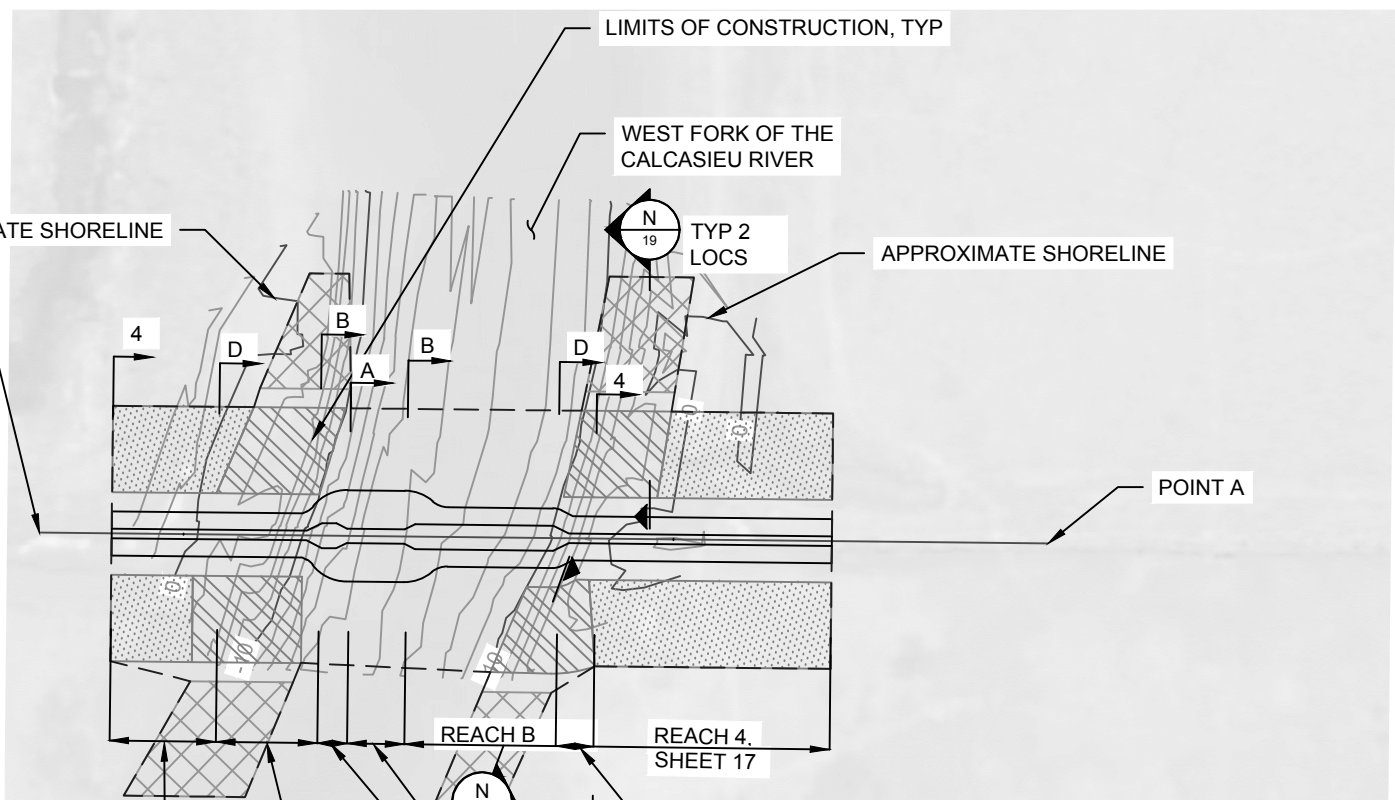

WEST PASS QUANTITY SUMMARY	
TYPE	QUANTITY
WALL LENGTH	749 LF
WALL AREA	0.97 ACRES
ROCK VOLUME	39,613 CY
PERMANENT DREDGE AREA	0.00 ACRES
PERMANENT DREDGE VOLUME	0 CY
TEMPORARY ACCESS FLOTATION DREDGING AREA	0.69 ACRES
TEMPORARY ACCESS FLOTATION DREDGING VOLUME	4,976 CY
TEMPORARY SPOIL PLACEMENT AREA	0.79 ACRES
TEMPORARY ACCESS CORRIDOR AREA	1.32 ACRES

WEST PASS ESTIMATED IMPACT	
TYPE	QUANTITY
PERMANENT IMPACTED VEGETATED WETLANDS	0.36 ACRES
TEMPORARY IMPACTED VEGETATED WETLANDS	1.20 ACRES
PERMANENT IMPACTED SUBMERGED BOTTOM	0.61 ACRES
TEMPORARY IMPACTED SUBMERGED BOTTOM	1.48 ACRES

ALIGNMENT TABLE		
P####	LATITUDE	LONGITUDE
A	N29° 49' 21.66"	W93° 21' 27.33"
B	N29° 49' 32.05"	W93° 21' 27.21"

MHW= +0.77 FT  
MHW= -0.09 FT  
(NAVD 88)

PROPOSED SALINITY BARRIER  
= 749 LINEAR FEET.

**WEST PASS**  
SCALE: 1" = 400'

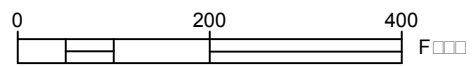

APPLICATION BY: COASTAL PROTECTION AND RESTORATION AUTHORITY 150 TERRACE STREET BATON ROUGE, LA 70802		CALCASIEU SALINITY CONTROL MEASURES	WEST PASS
			STATE PROJECT NUMBER: CS-65
DRAWN BY: VR	DESIGNED BY: LRM	APPROVED BY: BR	FEDERAL PROJECT NUMBER: SHEET 6 OF 19

**NOTES:**

1. REFER TO TABLE FOR SHEET PILE SECTION AND TIP ELEVATION
2. PAINT TOP TEN FEET OF SHEET PILES.
3. CROSS SECTIONS SHOW GEOMETRY AT END OF CONSTRUCTION.
4. TYP TOP OF BERM EL AFTER SHORT TERM SETTLEMENT.
5. OVERLAP GEOTEXTILE AGAINST SHEET PILE.
6. INCREASE BEDDING STONE THICKNESS AS REQUIRED TO REACH TOP OF BERM THICKNESS.

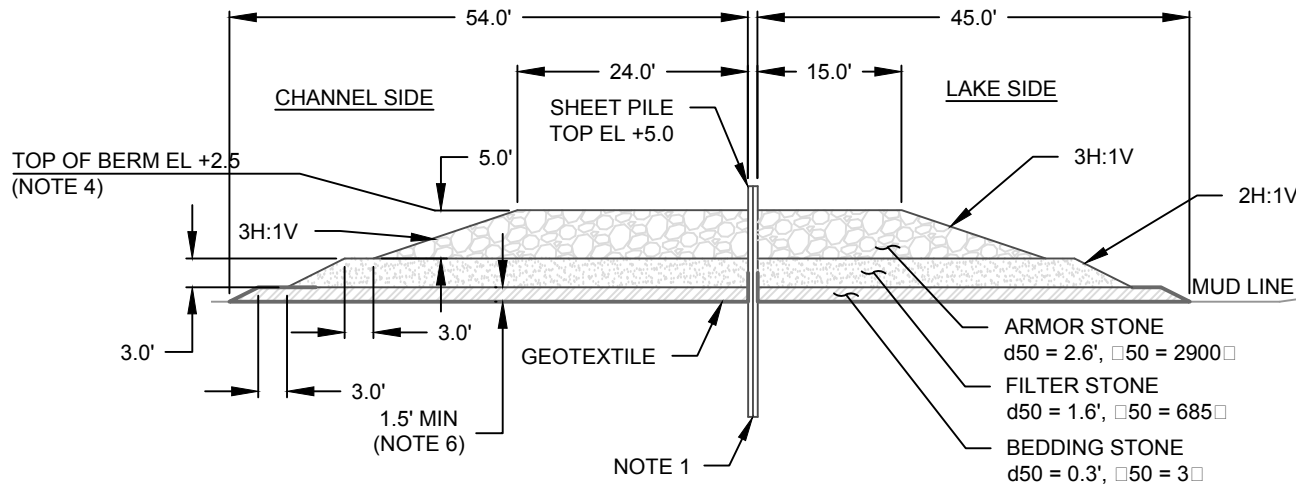

**E WALL - SECTION**  
SCALE: 1"=20'

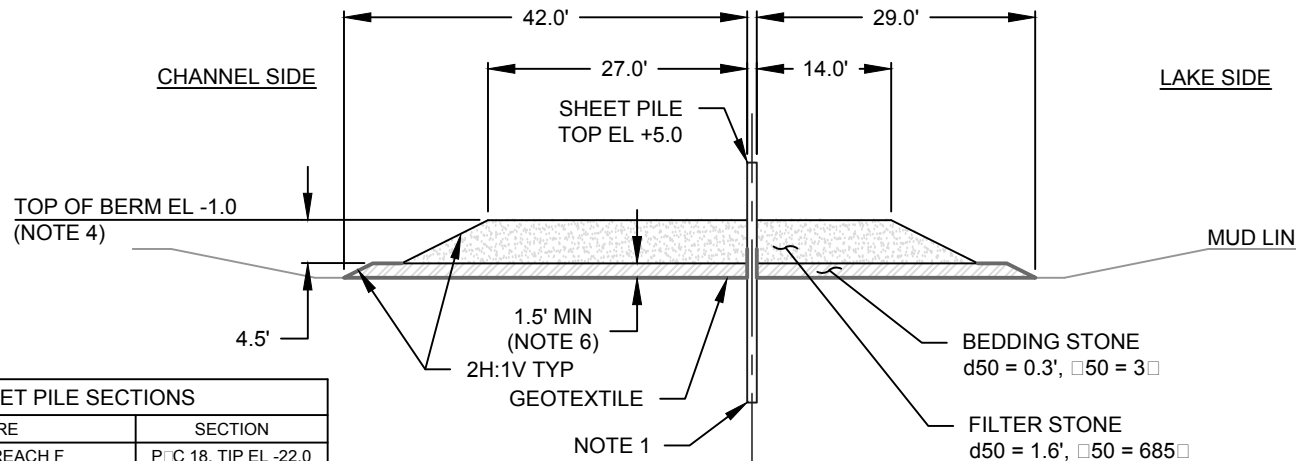

**F WALL - SECTION**  
SCALE: 1"=20'

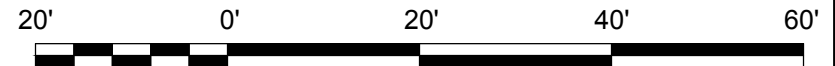

SHEET PILE SECTIONS	
FEATURE	SECTION
JOE'S CUT, REACH F	P.C 18, TIP EL -22.0
EAST PASS, REACH C □ D	P.C 26, TIP EL -35.0
WEST PASS, REACH C □ D	P.C 26, TIP EL -35.0
LAKE WALL	P.C 18, TIP EL -26.0
NINE MILE CUT	P.C 13, TIP EL -25.0

APPLICATION BY: COASTAL PROTECTION AND RESTORATION AUTHORITY 150 TERRACE STREET BATON ROUGE, LA 70802	<b>COASTAL PROTECTION AND RESTORATION AUTHORITY</b> 150 TERRACE STREET BATON ROUGE, LOUISIANA 70802	CALCASIEU SALINITY CONTROL MEASURES	CROSS SECTIONS E - F
		STATE PROJECT NUMBER: CS-65	DATE: 20-APR-2018
DRAWN BY: SPF	DESIGNED BY: LRM	APPROVED BY: BR	FEDERAL PROJECT NUMBER: SHEET 7 OF 19

ALIGNMENT TABLE		
P	LATITUDE	LONGITUDE
A	N29° 51' 02.65"	W93° 21' 05.35"
B	N29° 50' 53.18"	W93° 21' 07.16"
C	N29° 50' 41.34"	W93° 21' 08.24"
D	N29° 50' 33.14"	W93° 21' 07.60"

JOE'S CUT QUANTITY SUMMARY	
TYPE	QUANTITY
WALL LENGTH	2,218 LF
WALL AREA	3.51 ACRES
ROCK VOLUME	94,277 CY
PERMANENT DREDGE AREA	1.39 ACRES
PERMANENT DREDGE VOLUME	5,013 CY
TEMPORARY ACCESS FLOTATION DREDGING AREA	4.84 ACRES
TEMPORARY ACCESS FLOTATION DREDGING VOLUME	35,132 CY
TEMPORARY SPOIL PLACEMENT AREA	6.36 ACRES
TEMPORARY ACCESS CORRIDOR AREA	2.91 ACRES

JOE'S CUT ESTIMATED IMPACT	
TYPE	QUANTITY
PERMANENT IMPACTED VEGETATED WETLANDS	1.11 ACRES
TEMPORARY IMPACTED VEGETATED WETLANDS	2.76 ACRES
PERMANENT IMPACTED SUBMERGED BOTTOM	2.18 ACRES
TEMPORARY IMPACTED SUBMERGED BOTTOM	11.20 ACRES

MHW=+ 0.77 FT  
MLW=+ 0.03 FT  
(NAVD88)

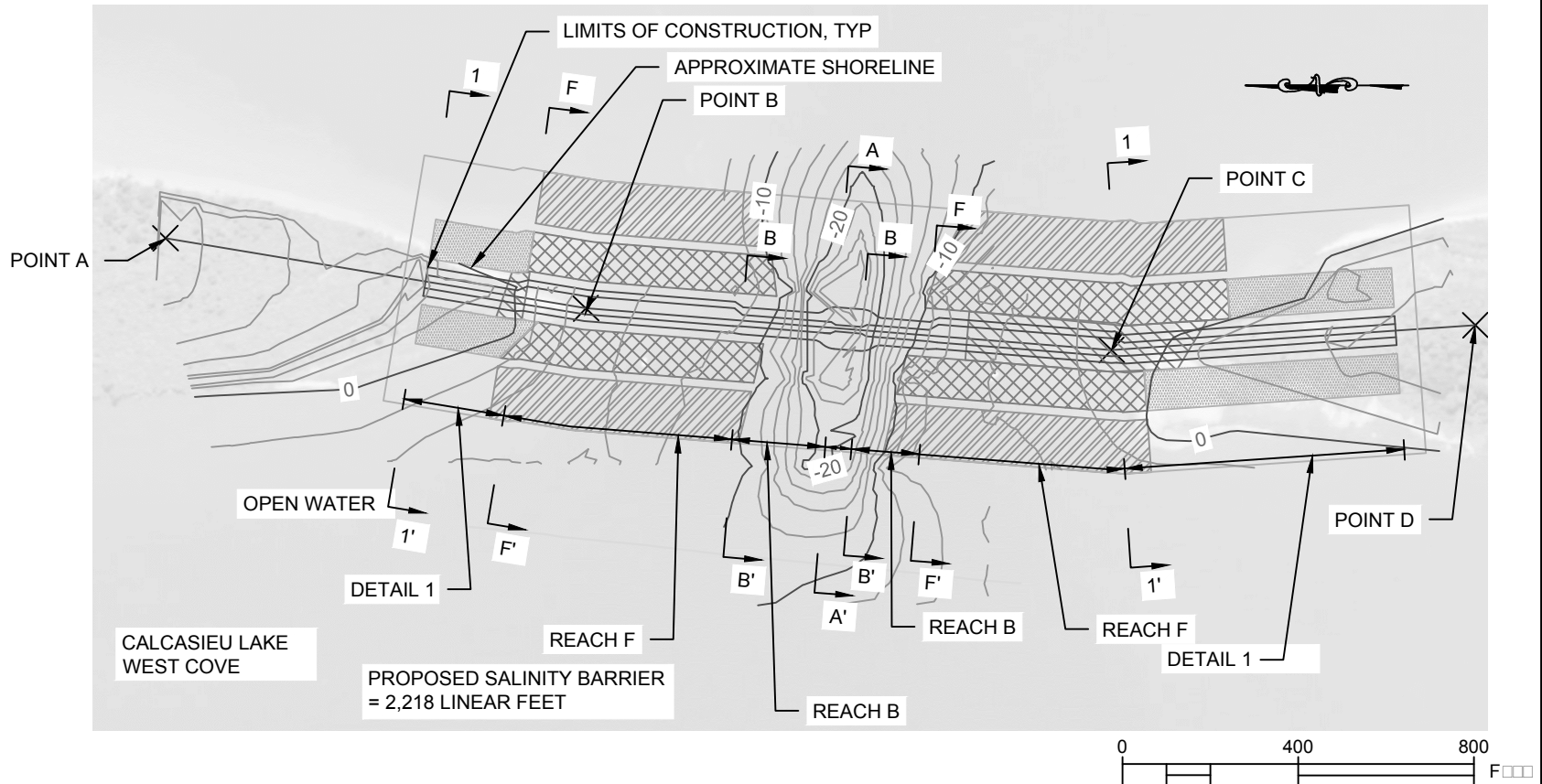

APPLICATION BY: COASTAL PROTECTION AND RESTORATION AUTHORITY 150 TERRACE STREET BATON ROUGE, LA 70802	 150 TERRACE STREET BATON ROUGE, LOUISIANA 70802	CALCASIEU SALINITY CONTROL MEASURES	JOE'S CUT
		STATE PROJECT NUMBER: CS-65	DATE: 20-APR-2018
DRAWN BY: VR	DESIGNED BY: LRM	APPROVED BY: BR	FEDERAL PROJECT NUMBER: SHEET 8 OF 19

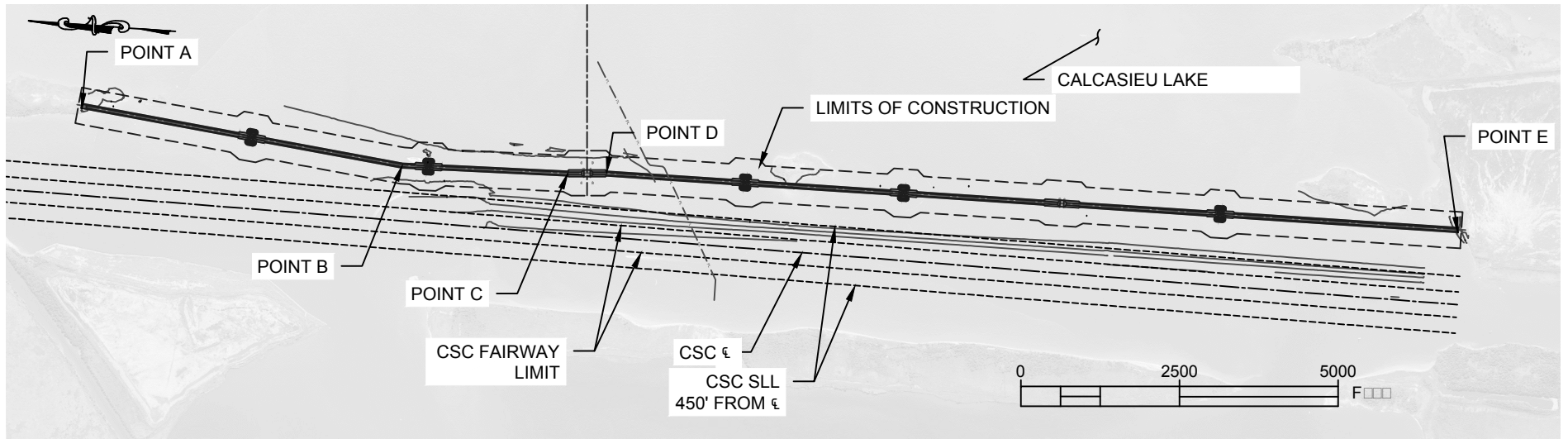

**LAKE WALL**

SCALE: 1" = 2500'

PROPOSED SALINITY BARRIER  
= 21,830 LINEAR FEET

MHW= +0.75 FT  
MLW= +0.02 FT  
(NAVD 88)

ALIGNMENT TABLE		
Point	LATITUDE	LONGITUDE
A	N29° 53' 54.55"	W93° 20' 16.74"
B	N29° 53' 03.83"	W93° 20' 27.57"
C	N29° 52' 37.97"	W93° 20' 29.01"
D	N29° 52' 32.03"	W93° 20' 29.00"
E	N29° 50' 17.96"	W93° 20' 39.20"

LAKE WALL QUANTITY SUMMARY	
TYPE	QUANTITY
WALL LENGTH	21,830 LF
WALL AREA	42.50 ACRES
ROCK VOLUME	952,957 CY
PERMANENT DREDGE AREA	25.95 ACRES
PERMANENT DREDGE VOLUME	83,729 CY
TEMPORARY ACCESS FLOTATION DREDGING AREA	89.02 ACRES
TEMPORARY ACCESS FLOTATION DREDGING VOLUME	789,928 CY
TEMPORARY SPOIL PLACEMENT AREA	113.12 ACRES
TEMPORARY ACCESS CORRIDOR AREA	1.51 ACRES

LAKE WALL ESTIMATED IMPACT	
TYPE	QUANTITY
PERMANENT IMPACTED VEGETATED WETLANDS	0.53 ACRES
TEMPORARY IMPACTED VEGETATED WETLANDS	1.40 ACRES
PERMANENT IMPACTED SUBMERGED BOTTOM	41.93 ACRES
TEMPORARY IMPACTED SUBMERGED BOTTOM	202.14 ACRES

APPLICATION BY: COASTAL PROTECTION AND RESTORATION AUTHORITY 150 TERRACE STREET BATON ROUGE, LA 70802		CALCASIEU SALINITY CONTROL MEASURES	LAKE WALL KEY PLAN
			STATE PROJECT NUMBER: CS-65
DRAWN BY: VR	DESIGNED BY: LRM	APPROVED BY: BR	FEDERAL PROJECT NUMBER: SHEET 9 OF 19

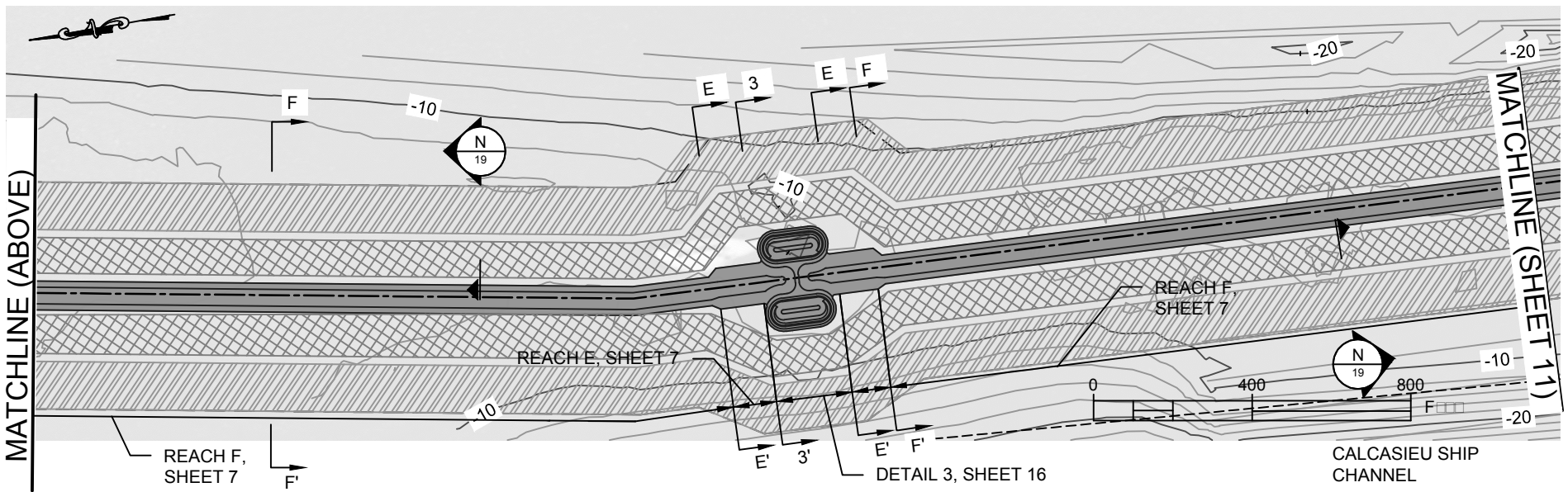
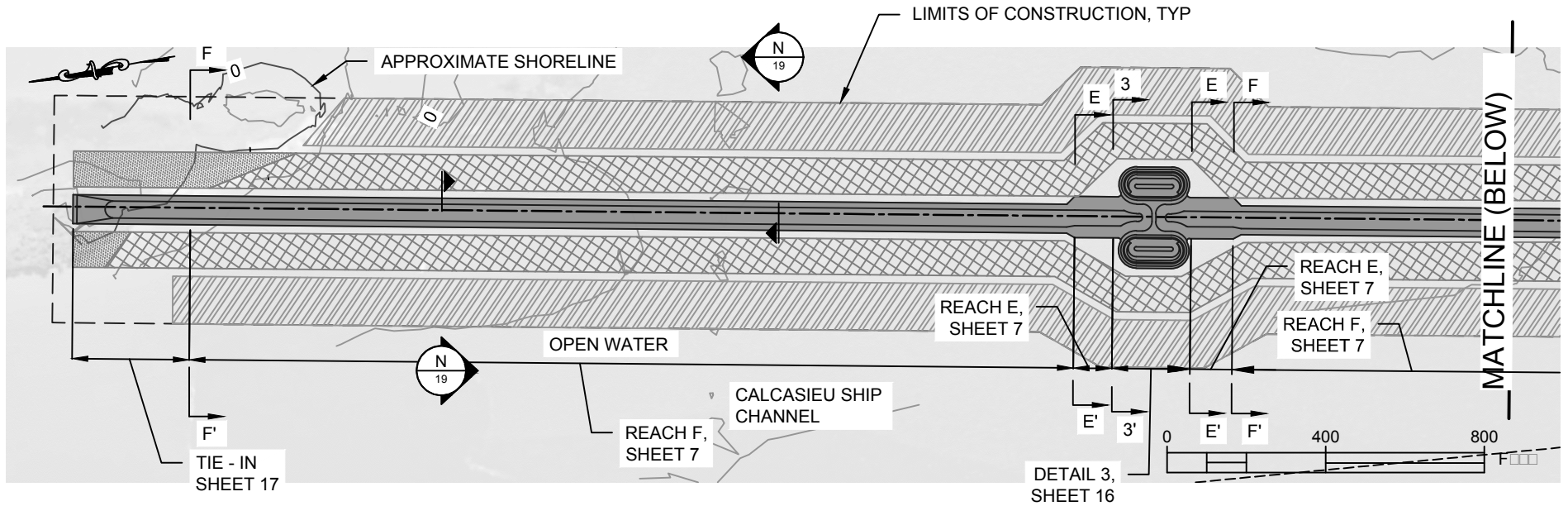

APPLICATION BY: COASTAL PROTECTION AND RESTORATION AUTHORITY 150 TERRACE STREET BATON ROUGE, LA 70802		<b>COASTAL PROTECTION AND RESTORATION AUTHORITY</b> 150 TERRACE STREET BATON ROUGE, LOUISIANA 70802	CALCASIEU SALINITY CONTROL MEASURES	LAKE WALL 1 OF 3
DRAWN BY: VR	DESIGNED BY: LRM	APPROVED BY: BR	STATE PROJECT NUMBER: CS-65  FEDERAL PROJECT NUMBER:	DATE: 20-APR-2018  SHEET 10 OF 19

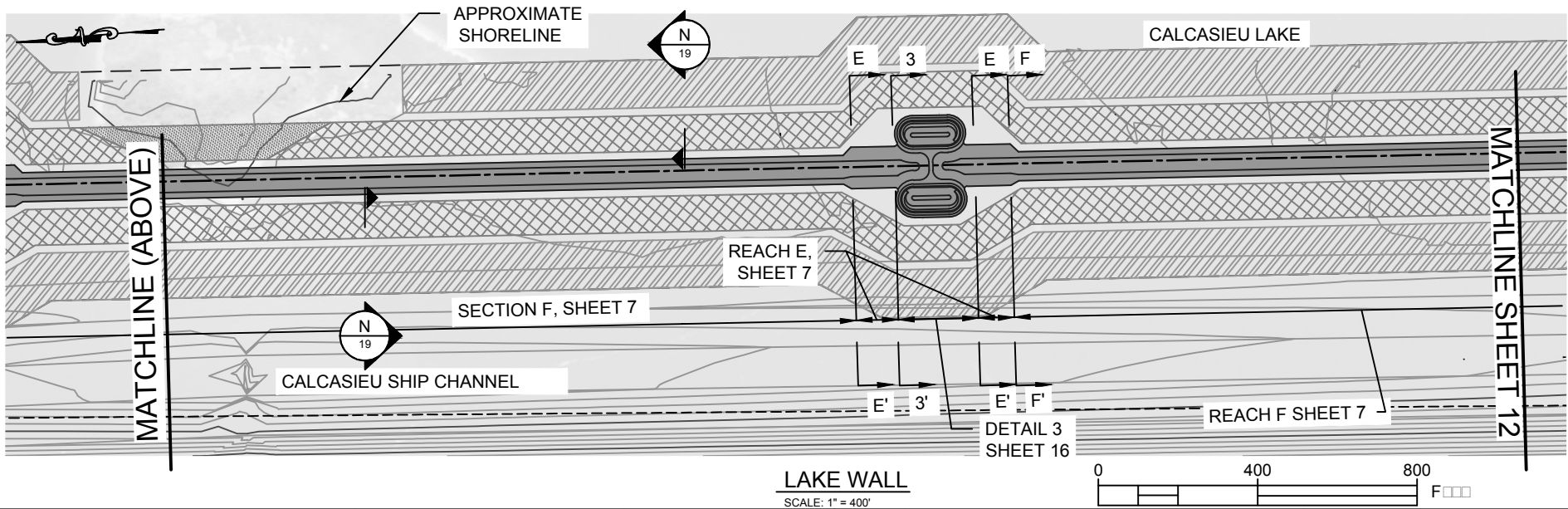
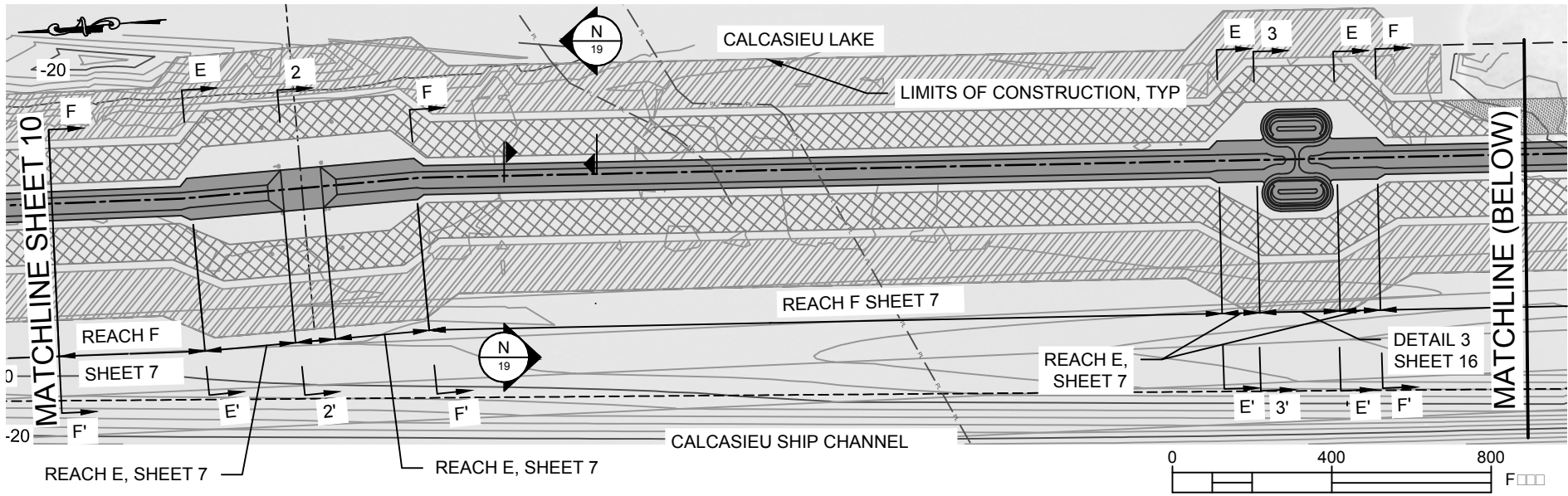

**LAKE WALL**  
SCALE: 1" = 400'

APPLICATION BY: COASTAL PROTECTION AND RESTORATION AUTHORITY 150 TERRACE STREET BATON ROUGE, LA 70802		<b>COASTAL PROTECTION AND RESTORATION AUTHORITY</b> 150 TERRACE STREET BATON ROUGE, LOUISIANA 70802	CALCASIEU SALINITY CONTROL MEASURES	LAKE WALL 2 OF 3
DRAWN BY: VR	DESIGNED BY: LRM	APPROVED BY: BR	STATE PROJECT NUMBER: CS-65  FEDERAL PROJECT NUMBER:	DATE: 20-APR-2018  SHEET 11 OF 19

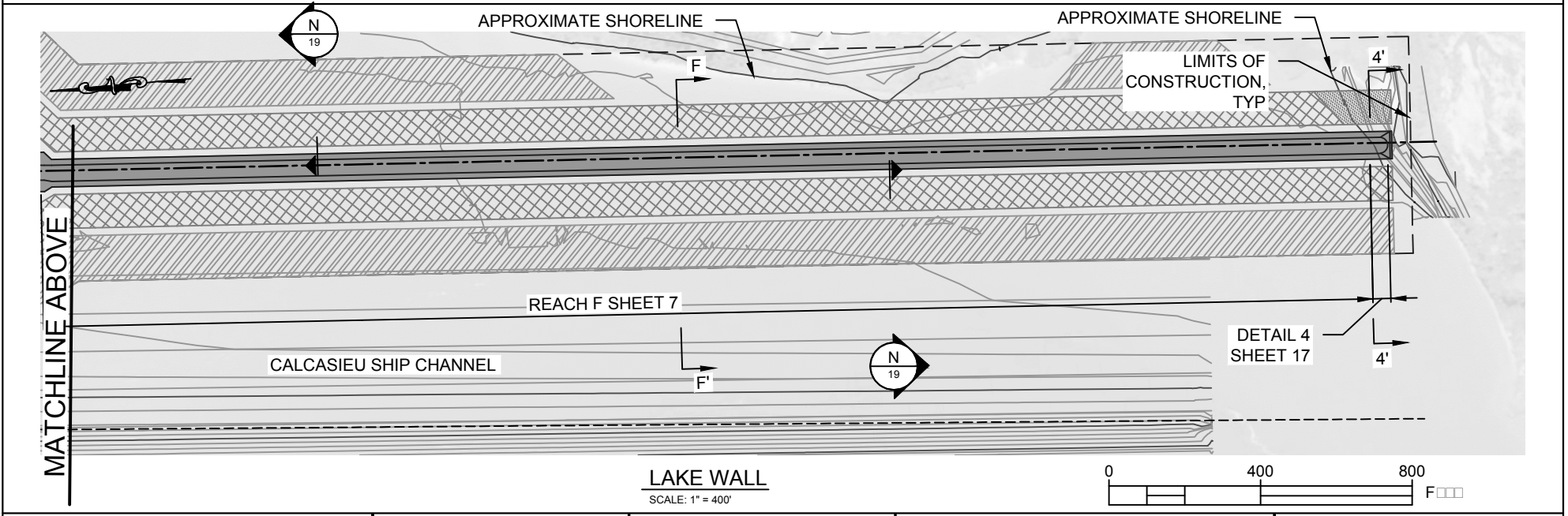
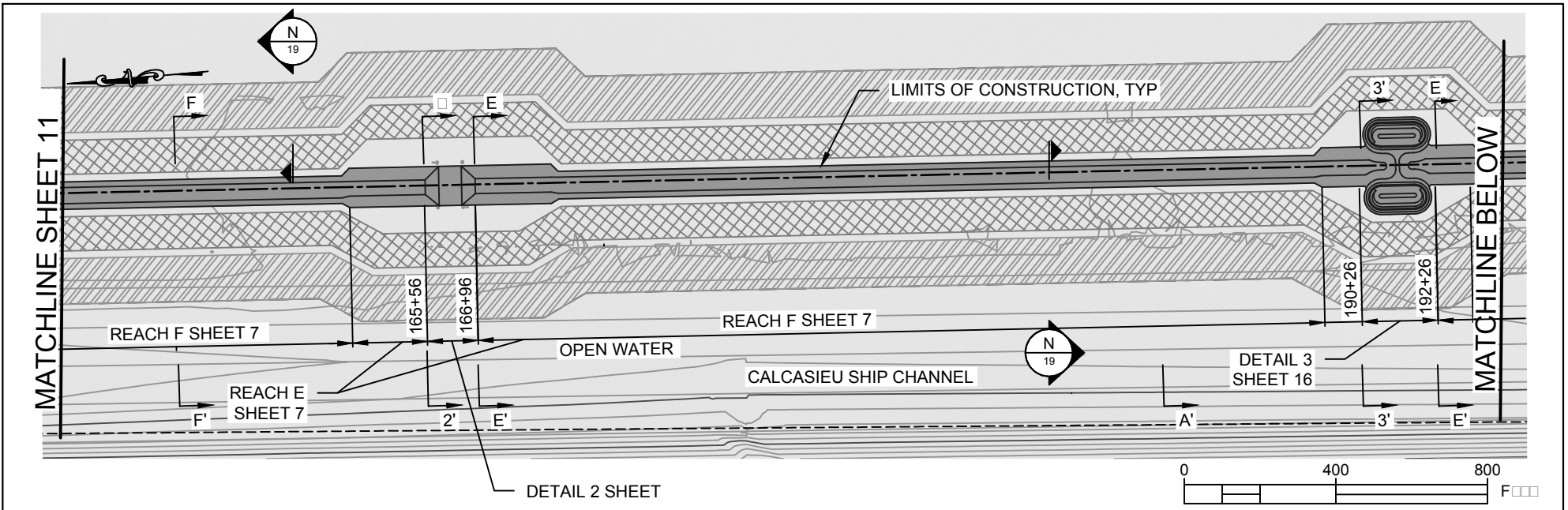

APPLICATION BY: COASTAL PROTECTION AND RESTORATION AUTHORITY 150 TERRACE STREET BATON ROUGE, LA 70802	<p style="text-align: center;"><b>LAKE WALL</b></p> <p style="text-align: center;">SCALE: 1" = 400'</p>	<b>COASTAL PROTECTION AND RESTORATION AUTHORITY</b> 150 TERRACE STREET BATON ROUGE, LOUISIANA 70802	CALCASIEU SALINITY CONTROL MEASURES	LAKE WALL 3 OF 3
DRAWN BY: VR	DESIGNED BY: LRM	APPROVED BY: BR	STATE PROJECT NUMBER: CS-65  FEDERAL PROJECT NUMBER:	DATE: 20-APR-2018  SHEET 12 OF 19

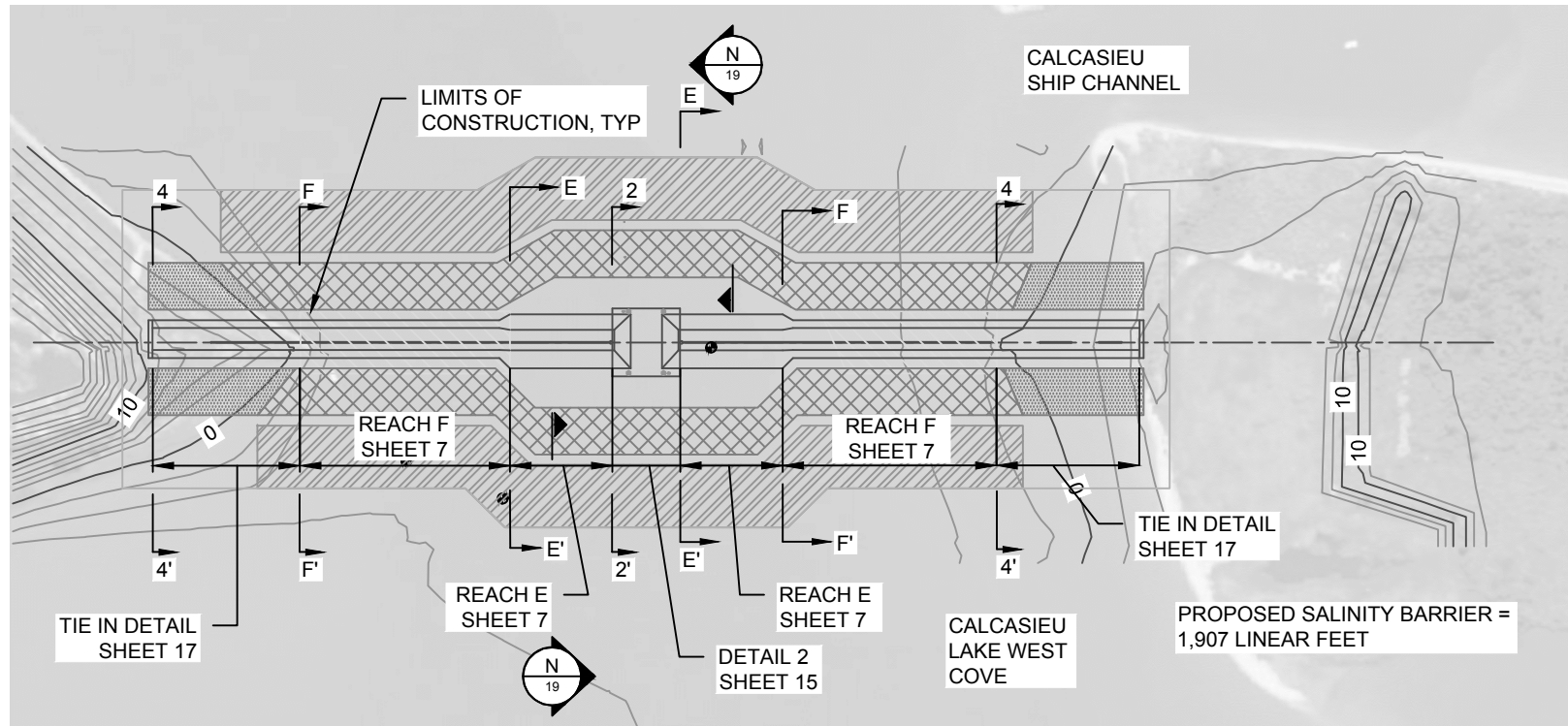

**MNE MILE CUT**

SCALE: 1" = 400'

ALIGNMENT TABLE		
P	LATITUDE	LONGITUDE
A	N29° 53' 21.39"	W93° 20' 55.68"
B	N29° 52' 53.68"	W93° 20' 55.12"

NINE MILE CUT ESTIMATED IMPACT	
TYPE	QUANTITY
PERMANENT IMPACTED VEGETATED WETLANDS	0.66 ACRES
TEMPORARY IMPACTED VEGETATED WETLANDS	1.60 ACRES
PERMANENT IMPACTED SUBMERGED BOTTOM	2.98 ACRES
TEMPORARY IMPACTED SUBMERGED BOTTOM	14.60 ACRES

NINE MILE CUT QUANTITY SUMMARY	
TYPE	QUANTITY
WALL LENGTH	1,907 LF
WALL AREA	3.91 ACRES
ROCK VOLUME	84,066 CY
PERMANENT DREDGE AREA	1.97 ACRES
PERMANENT DREDGE VOLUME	7,049 CY
TEMPORARY ACCESS FLOTATION DREDGING AREA	6.00 ACRES
TEMPORARY ACCESS FLOTATION DREDGING VOLUME	48,434 CY
TEMPORARY SPOIL PLACEMENT AREA	8.60 ACRES
TEMPORARY ACCESS CORRIDOR AREA	1.88 ACRES

MHW= +0.75 FT  
MLW= +0.01 FT  
(NAVD 88)

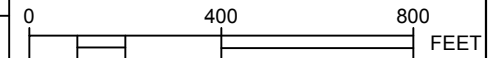

APPLICATION BY:  
COASTAL PROTECTION AND RESTORATION AUTHORITY  
150 TERRACE STREET  
BATON ROUGE, LA 70802

DRAWN BY: SPF

DESIGNED BY: LRM

**COASTAL PROTECTION AND RESTORATION AUTHORITY**  
150 TERRACE STREET  
BATON ROUGE, LOUISIANA 70802

APPROVED BY: BR

CALCASIEU SALINITY CONTROL MEASURES

STATE PROJECT NUMBER: CS-65

FEDERAL PROJECT NUMBER:

NINE MILE CUT

DATE: 20-APR-2018

SHEET 13 OF 19



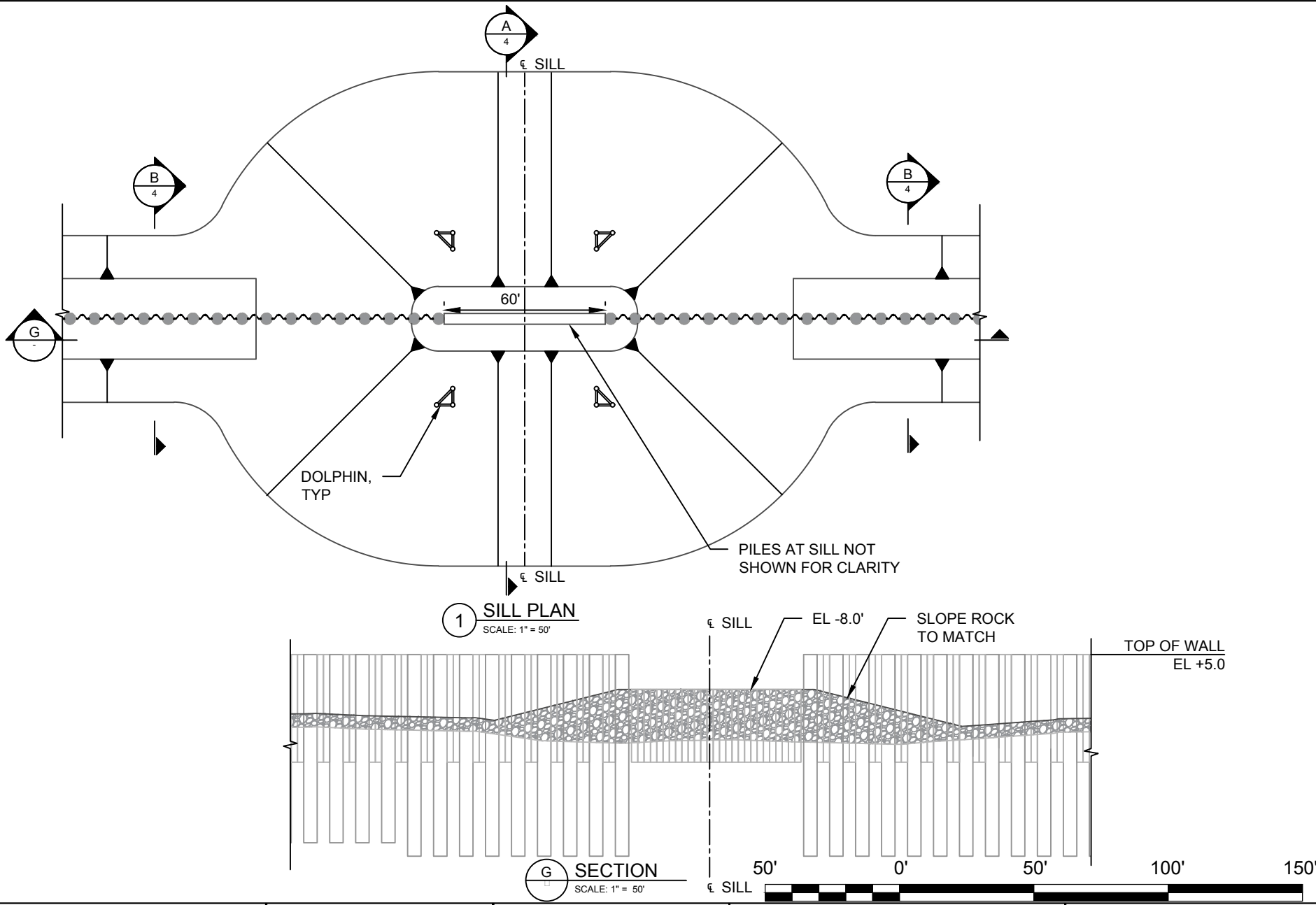

APPLICATION BY:  
 COASTAL PROTECTION AND RESTORATION AUTHORITY  
 150 TERRACE STREET  
 BATON ROUGE, LA 70802

**COASTAL PROTECTION  
 AND RESTORATION  
 AUTHORITY**  
 150 TERRACE STREET  
 BATON ROUGE, LOUISIANA 70802

CALCASIEU SALINITY  
 CONTROL MEASURES

STATE PROJECT NUMBER: CS-65

FEDERAL PROJECT NUMBER:

SILL DETAIL  
 1

DATE: 20-APR-2018

SHEET 14 OF 19

DRAWN BY: VR

DESIGNED BY: LRM

APPROVED BY: BR

FEDERAL PROJECT NUMBER:

SHEET 14 OF 19

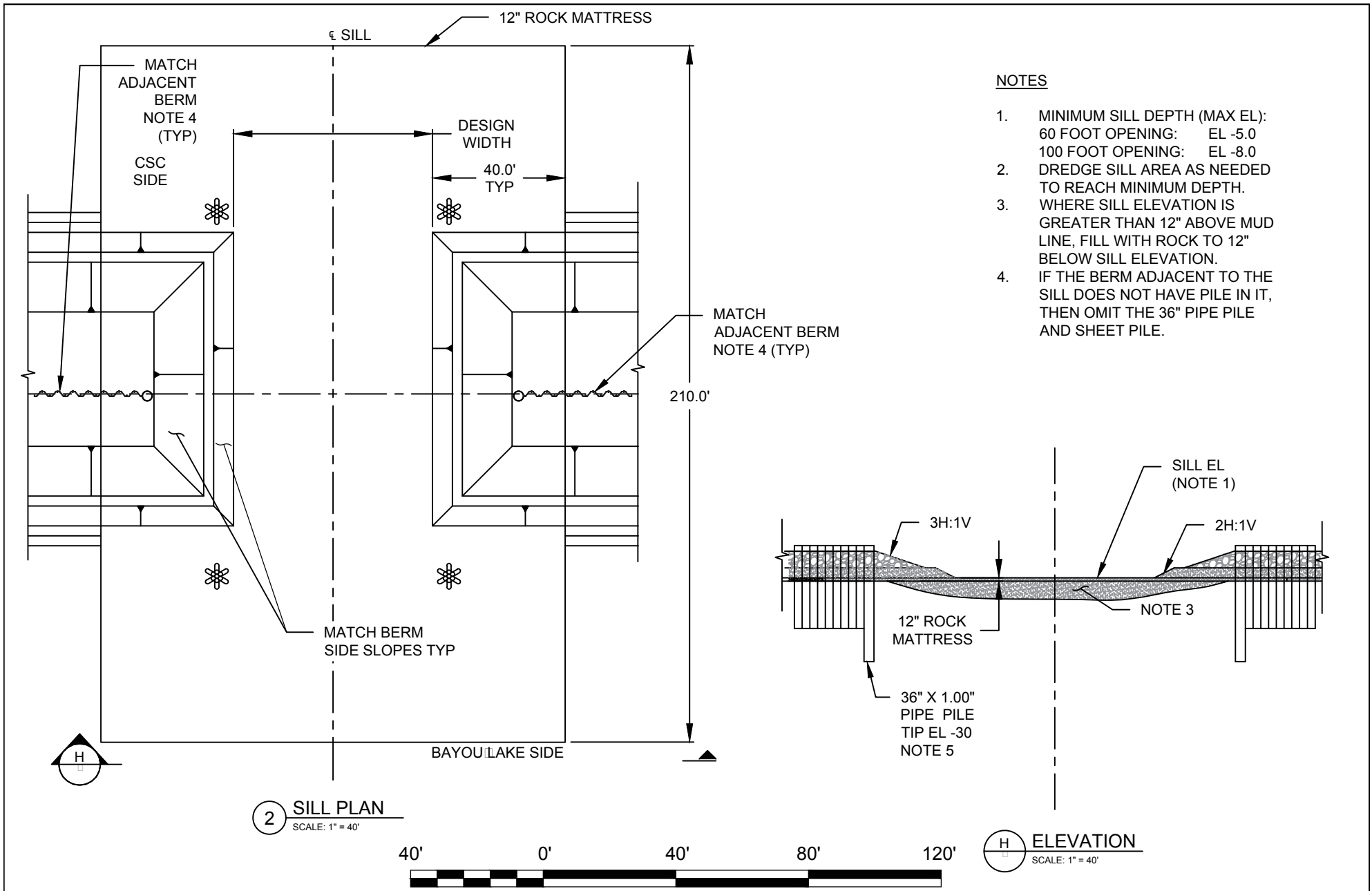

APPLICATION BY: COASTAL PROTECTION AND RESTORATION AUTHORITY 150 TERRACE STREET BATON ROUGE, LA 70802		<b>COASTAL PROTECTION AND RESTORATION AUTHORITY</b> 150 TERRACE STREET BATON ROUGE, LOUISIANA 70802	CALCASIEU SALINITY CONTROL MEASURES	SILL DETAIL 2
DRAWN BY: VR	DESIGNED BY: LRM	APPROVED BY: BR	STATE PROJECT NUMBER: CS-65  FEDERAL PROJECT NUMBER:	DATE: 20-APR-2018  SHEET 15 OF 19

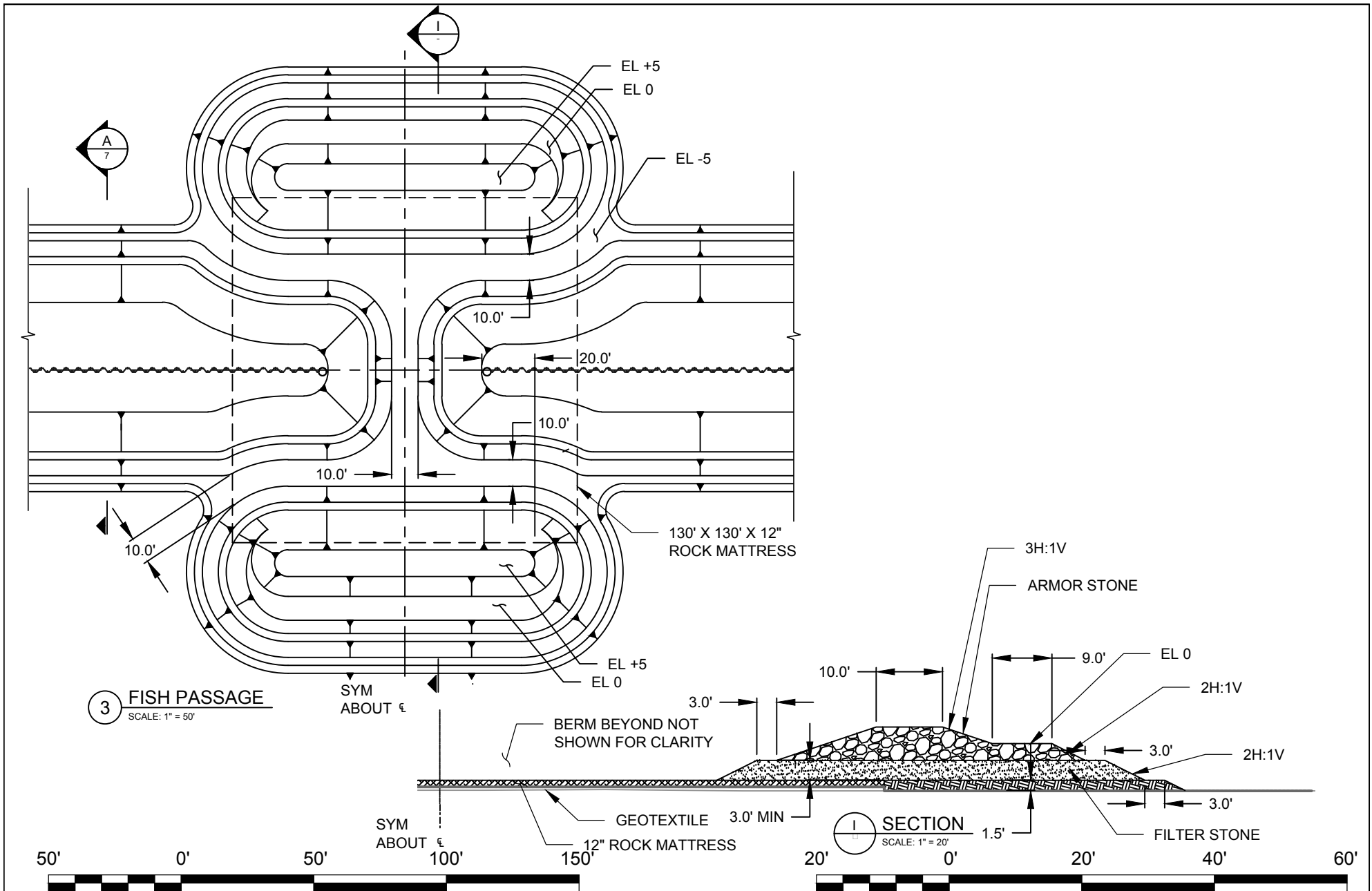

**3 FISH PASSAGE**  
SCALE: 1" = 50'

**SECTION**  
SCALE: 1" = 20'

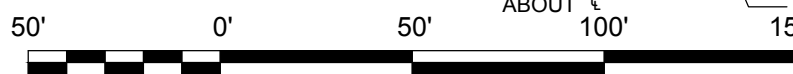

APPLICATION BY: COASTAL PROTECTION AND RESTORATION AUTHORITY 150 TERRACE STREET BATON ROUGE, LA 70802		<b>COASTAL PROTECTION AND RESTORATION AUTHORITY</b> 150 TERRACE STREET BATON ROUGE, LOUISIANA 70802	CALCASIEU SALINITY CONTROL MEASURES	FISH PASSAGE
DRAWN BY: VR	DESIGNED BY: LRM	APPROVED BY: BR	STATE PROJECT NUMBER: CS-65 FEDERAL PROJECT NUMBER:	DATE: 20-APR-2018 SHEET 16 OF 19

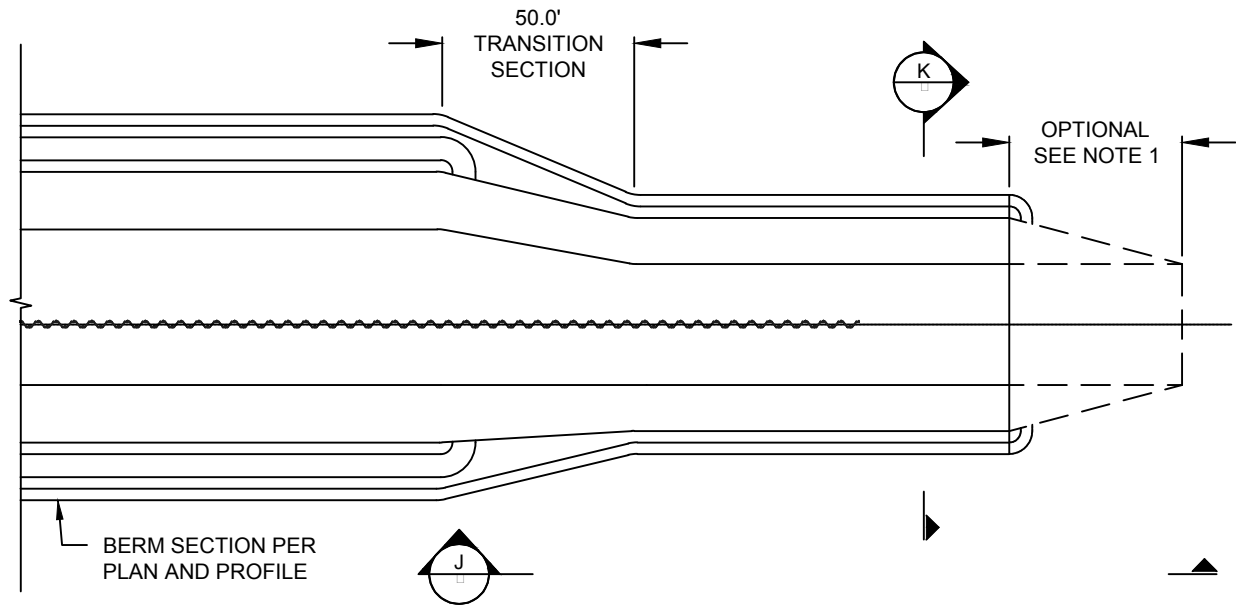

**NOTES**

1. WHERE TIE-IN ENDS AND THERE IS NO EXISTING GRADE AT OR ABOVE EL. +7.5, SLOPE DOWN ROCK AT 10H:1V.
2. SHEET PILE TIP EL MATCHES ADJACENT BERM SECTION.
3. REFER TO PLAN FOR THE LOCATION OF THE END OF THE SHEET PILE.

BERM SECTION PER PLAN AND PROFILE

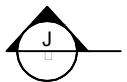

**4 TIE-IN DETAIL**  
SCALE: 1" = 50'

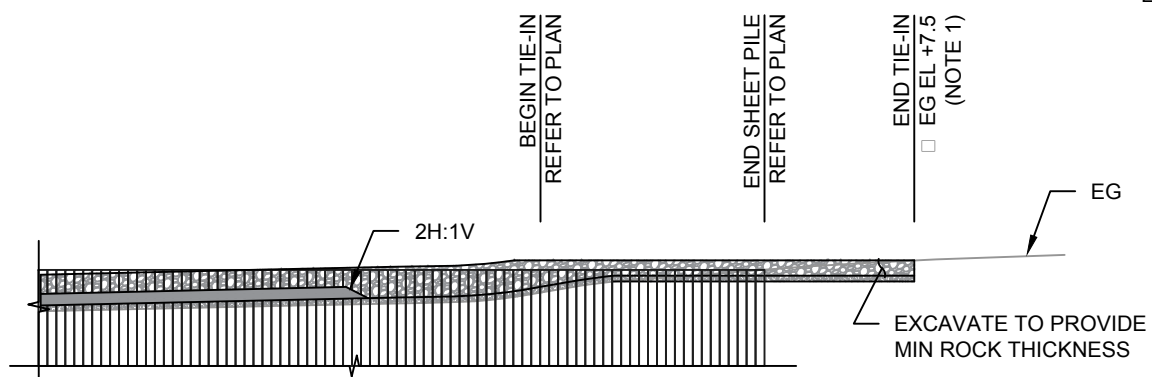

**J ELEVATION**  
SCALE: 1" = 50'

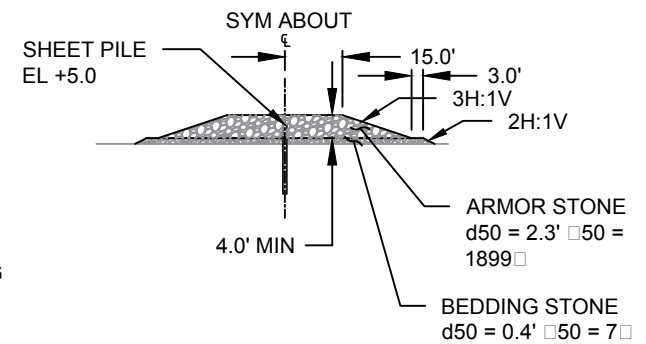

**K SECTION**  
SCALE: 1" = 50'

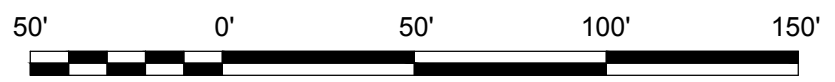

APPLICATION BY: COASTAL PROTECTION AND RESTORATION AUTHORITY 150 TERRACE STREET BATON ROUGE, LA 70802		<b>COASTAL PROTECTION AND RESTORATION AUTHORITY</b> 150 TERRACE STREET BATON ROUGE, LOUISIANA 70802	CALCASIEU SALINITY CONTROL MEASURES	TIE-IN DETAIL 1
DRAWN BY: VR	DESIGNED BY: LRM	APPROVED BY: BR	STATE PROJECT NUMBER: CS-65  FEDERAL PROJECT NUMBER:	DATE: 20-APR-2018  SHEET 17 OF 19

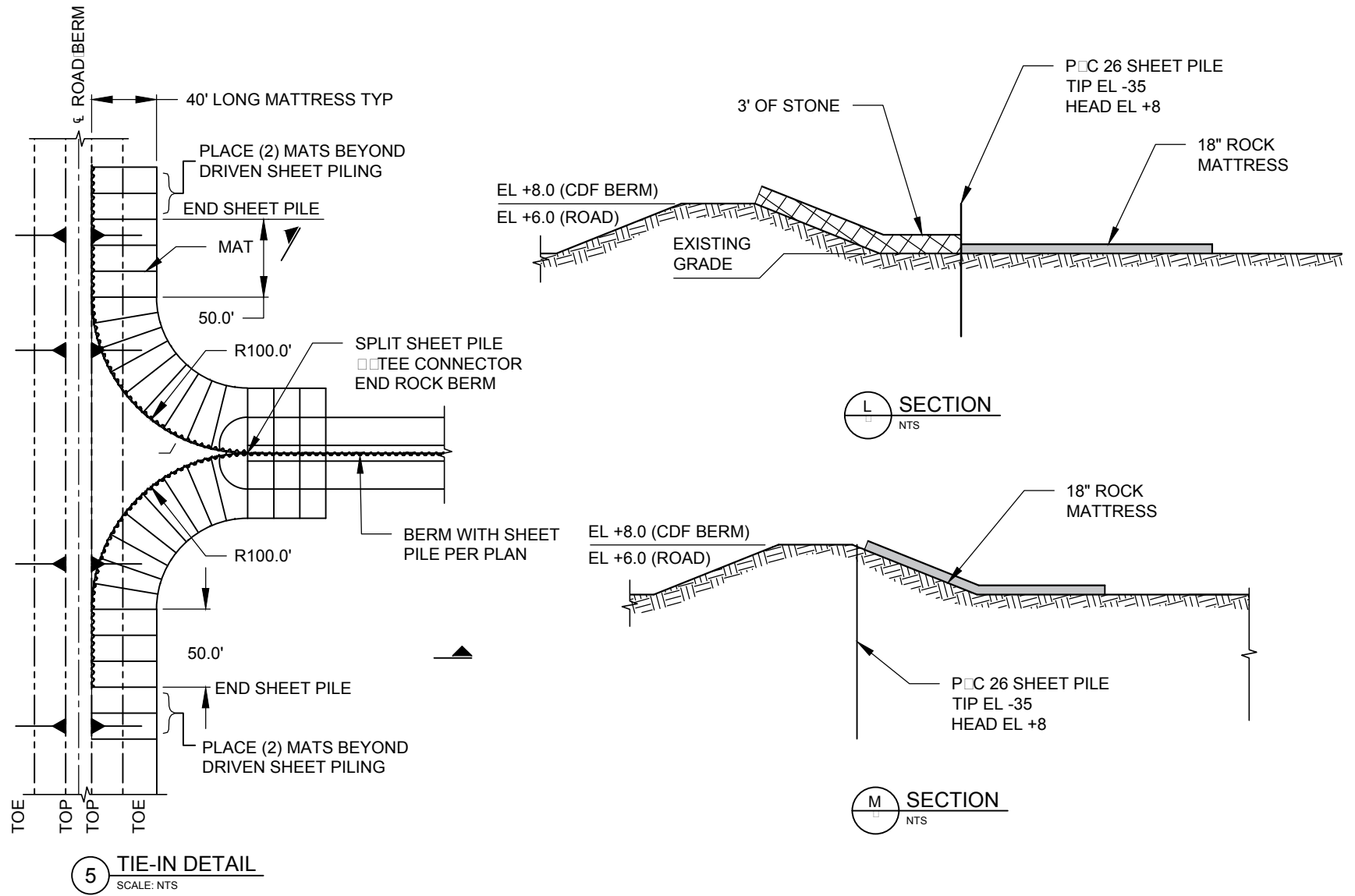

APPLICATION BY: COASTAL PROTECTION AND RESTORATION AUTHORITY 150 TERRACE STREET BATON ROUGE, LA 70802		<b>COASTAL PROTECTION AND RESTORATION AUTHORITY</b> 150 TERRACE STREET BATON ROUGE, LOUISIANA 70802	CALCASIEU SALINITY CONTROL MEASURES	TIE-IN DETAIL 2
DRAWN BY: VR	DESIGNED BY: LRM	APPROVED BY: BR	STATE PROJECT NUMBER: CS-65	DATE: 20-APR-2018
			FEDERAL PROJECT NUMBER:	SHEET 18 OF 19

**NOTE:**

1. TEMPORARY ACCESS CHANNEL AS REQUIRED FOR CONSTRUCTION ACCESS. REFER TO PLANS FOR ESTIMATED EXTENTS. REFER TO NOTE 4, SHEET 2.

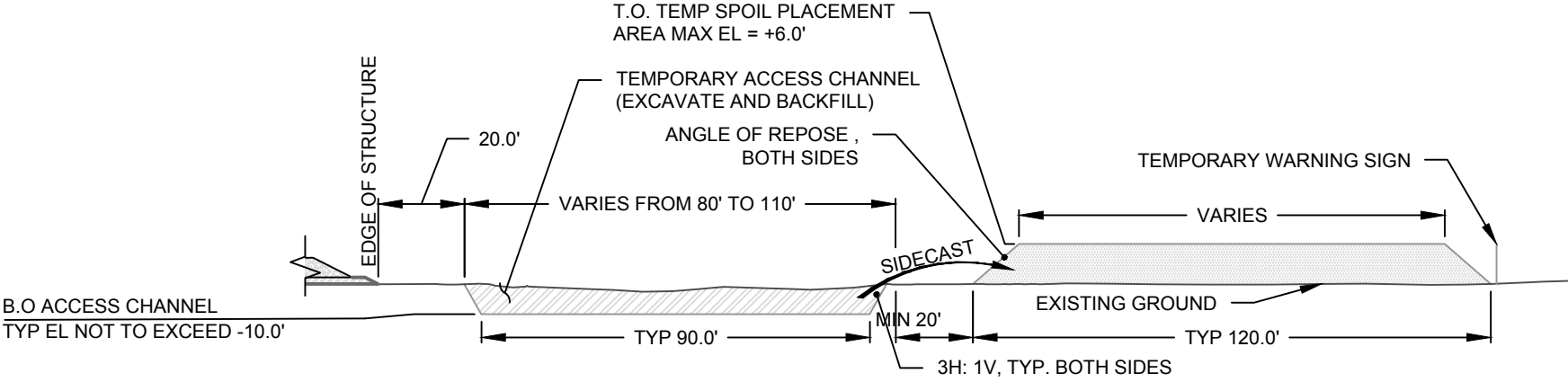

B.O ACCESS CHANNEL  
TYP EL NOT TO EXCEED -10.0'

**ACCESS CHANNEL TYPICAL SECTION**  
SCALE: 1" = 40'

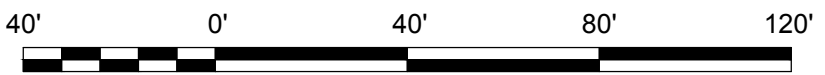

APPLICATION BY: COASTAL PROTECTION AND RESTORATION AUTHORITY 150 TERRACE STREET BATON ROUGE, LA 70802		<b>COASTAL PROTECTION AND RESTORATION AUTHORITY</b> 150 TERRACE STREET BATON ROUGE, LOUISIANA 70802	CALCASIEU SALINITY CONTROL MEASURES	TEMPORARY ACCESS CHANNEL
DRAWN BY: SPF	DESIGNED BY: LRM	APPROVED BY: BR	STATE PROJECT NUMBER: CS-65	DATE: 20-APR-2018
			FEDERAL PROJECT NUMBER:	SHEET 19 OF 19