

# JOINT PUBLIC NOTICE

April 1, 2019

United States Army  
Corps of Engineers  
New Orleans District  
Attn: Regulatory Branch  
7400 Leake Avenue  
New Orleans, Louisiana 70118

State of Louisiana  
Department of Environmental Quality  
Attn: Office of Environmental Services  
Post Office Box 4313  
Baton Rouge, Louisiana 70821-4313

Project Manager: Dirreen Arnold  
(504) 862-2301 / fax: (504) 862-2574  
dirreen.s.arnold@usace.army.mil  
Permit Application Number:  
MVN-2018-00792-CA

Project Manager:  
Elizabeth Hill  
(225) 219-3225 / fax: (225) 219-3156  
WQC Application Number:  
WQC-190328-01

Interested parties are hereby notified that a permit application has been received by the New Orleans District of the US Army Corps of Engineers pursuant to:  Section 10 of the Rivers and Harbors Act of March 3, 1899 (30 Stat. 1151; 33 USC 403); and/or  Section 404 of the Clean Water Act (86 Stat. 816; 33 USC 1344).

Application has also been made to the Louisiana Department of Environmental Quality, Office of Environmental Services, for a Water Quality Certification (WQC) in accordance with statutory authority contained in LRS 30:2074 A(3) and provisions of Section 401 of the Clean Water Act.

## **BULKHEAD AND BACKFILL, BAYOU PETIT CAILLOU** **TERREBONNE PARISH**

**NAME OF APPLICANT:** LISA TILLMAN, 5298 Bayouside Drive, Chauvin, Louisiana 70344.

**LOCATION OF WORK:** Bayou Petit Caillou, in Section 20, Township 19 South, Range 18 East, identified as Lot 6009, located at 6009 Louisiana Highway 56, Chauvin, Louisiana, (29.405336, -90.608058), in Terrebonne Parish, as shown on the enclosed drawings, within Hydrologic Unit Code 08090302, West Central Louisiana Coastal, Louisiana.

The work described below was partially completed prior to obtaining a Department of the Army permit and was in violation of Section 10 of the Rivers and Harbor Act of 1899 and Section 301 of the Clean Water Act. All legal issues concerning the unauthorized work have since been deferred.

**CHARACTER OF WORK:** The applicant has requested after-the-fact Department of the Army authorization to install and maintain a 112-ft long bulkhead along Bayou Petit Caillou, and to place approximately 830 cubic yards of fill material behind the bulkhead for land reclamation. The structure will extend approximately 63 feet channelward where Bayou Petit Caillou's width is approximately 225 feet wide. Approximately 0.08 acre of non-wetland waters and approximately 0.003 acre wetland habitat will be impacted with the fill activities.

The applicant has stated that the project has been designed to avoid and minimize direct and secondary adverse impacts to the maximum extent practicable. If compensatory mitigation is required as a result of the proposed work, the applicant proposes to mitigate in-kind wetland credits from a Corps approved mitigation bank located in the watershed.

The comment period for the Department of the Army Permit and the Louisiana Department of Environmental Quality WQC will close **15 days** from the date of this joint public notice. Written comments, including suggestions for modifications or objections to the proposed work, stating reasons thereof, are being solicited from anyone having interest in this permit and/or this WQC request and must be submitted so as to be received before or by the last day of the comment period. Letters concerning the Corps of Engineers permit application must reference the applicant's name and the Permit Application Number, and be forwarded to the Corps of Engineers at the address above, **ATTENTION: REGULATORY BRANCH**. Similar letters concerning the Water Quality Certification must reference the applicant's name and the WQC application number and be mailed to the Louisiana Department of Environmental Quality at the address above. Individuals or parties may request an extension of time in which to comment on the proposed work by writing, faxing, or e-mailing the Corps of Engineers Project Manager listed above. Any request must be specific and substantively supportive of the requested extension, and received by this office prior to the end of the initial comment period. The Section Chief will review the request and the requestor will be promptly notified of the decision to grant or deny the request. If granted, the time extension will be continuous to the initial comment period and, inclusive of the initial comment period, will not exceed a total of 30 calendar days.

The application for this proposed project is on file with the Louisiana Department of Environmental Quality and may be examined during weekdays between 8:00 a.m. and 4:30 p.m. Copies may be obtained upon payment of costs of reproduction.

### **Corps of Engineers Permit Criteria**

The decision whether to issue a permit will be based on an evaluation of the probable impacts, including cumulative impacts of the proposed activity on the public interest. That decision will reflect the national concern for both protection and utilization of important resources. The benefit which reasonably may be expected to accrue from the proposal must be balanced against its reasonably foreseeable detriments. All factors which may be relevant to the proposal will be considered including the cumulative effects thereof; among those are conservation, economics, aesthetics, general environmental concerns, wetlands, historic properties, fish and wildlife values, flood hazards, floodplain values, land use, navigation, shoreline erosion and accretion, recreation, water supply and conservation, water quality, energy needs, safety, food and fiber production, mineral needs, considerations of property ownership and, in general, the needs and welfare of the people.

The U.S. Army Corps of Engineers is soliciting comments from the public, federal, state, and local agencies and officials, Indian Tribes, and other interested parties in order to consider and evaluate the impacts of this proposed activity. Any comments received will be considered by the U.S. Army Corps of Engineers to determine whether to make, modify, condition, or deny a permit for this proposal. To make this decision, comments are used to assess impacts on endangered species, historic properties, water quality, general environmental effects, and other public interest factors listed above. Comments are used in the preparation of an Environmental Assessment and/or an Environmental Impact Statement pursuant to the National Environmental Policy Act. Comments are also used to determine the need for a public hearing and to determine the overall public interest of the proposed activity.

The New Orleans District is unaware of properties listed on the National Register of Historic Places near the proposed work. The possibility exists that the proposed work may damage or destroy presently unknown archeological, scientific, pre-historical, historical sites, or data. Issuance of this public notice solicits input from the State Archeologist and State Historic Preservation Officer regarding potential impacts to cultural resources.

Our initial finding is that the proposed work would not affect any species, nor affect any habitat designated as critical to the survival and recovery of such species, listed as endangered by the U.S. Department of Interior. The New Orleans District has determined that the proposed project is located within waters known to be occupied by the endangered West Indian Manatee (*Trichechus manatus*) and determined with the inclusion of the Standard Manatee Conditions for In-Water Activities the proposed activity is not likely to adversely affect the species based on the Standard Local Operating Procedure for Endangered Species in Louisiana (SLOPES), dated October 22, 2014, between the U.S. Army Corps of Engineers, New Orleans and U.S. Fish and Wildlife Service, Ecological Services Office, the Corps has determined that with the inclusion of the Standard Manatee Conditions for In-Water Activities, the proposed work is not likely to adversely affect the West Indian Manatee.

This notice initiates the Essential Fish Habitat (EFH) consultation requirements of the Magnuson-Stevens Fishery Conservation and Management Act. The applicant's proposal may result in the destruction or alteration of 0.08 acres of EFH utilized by various life stages of red drum and penaeid shrimp. Our initial determination is that the proposed action would not have a substantial adverse impact on EFH or federally managed fisheries in the Gulf of Mexico. Our final determination relative to project impacts and the need for mitigation measures is subject to review by and coordination with the National Marine Fisheries Service.

If the proposed work involves deposits of dredged or fill material into navigable waters, the evaluation of the probable impacts will include the application of guidelines established by the Administrator of the Environmental Protection Agency. Also, a certification that the proposed activity will not violate applicable water quality standards will be required from the Department of Environmental Quality, before a permit is issued.

Any person may request, in writing, within the comment period specified in this notice, that a public hearing be held to consider this application. Requests for public hearings shall state, with particularity, the reasons for holding a public hearing. You are requested to communicate the information contained in this notice to any other parties whom you deem likely to have interest in the matter.

The applicant has certified that the proposed activity described in the application complies with and will be conducted in a manner that is consistent with the Louisiana Coastal Resources Program. The Department of the Army permit will not be issued unless the applicant received approval or a waiver of the Coastal Use Permit by the Department of Natural Resources.

JOHN M. HERMAN  
Chief, Central Evaluation Section  
Regulatory Branch

Enclosure

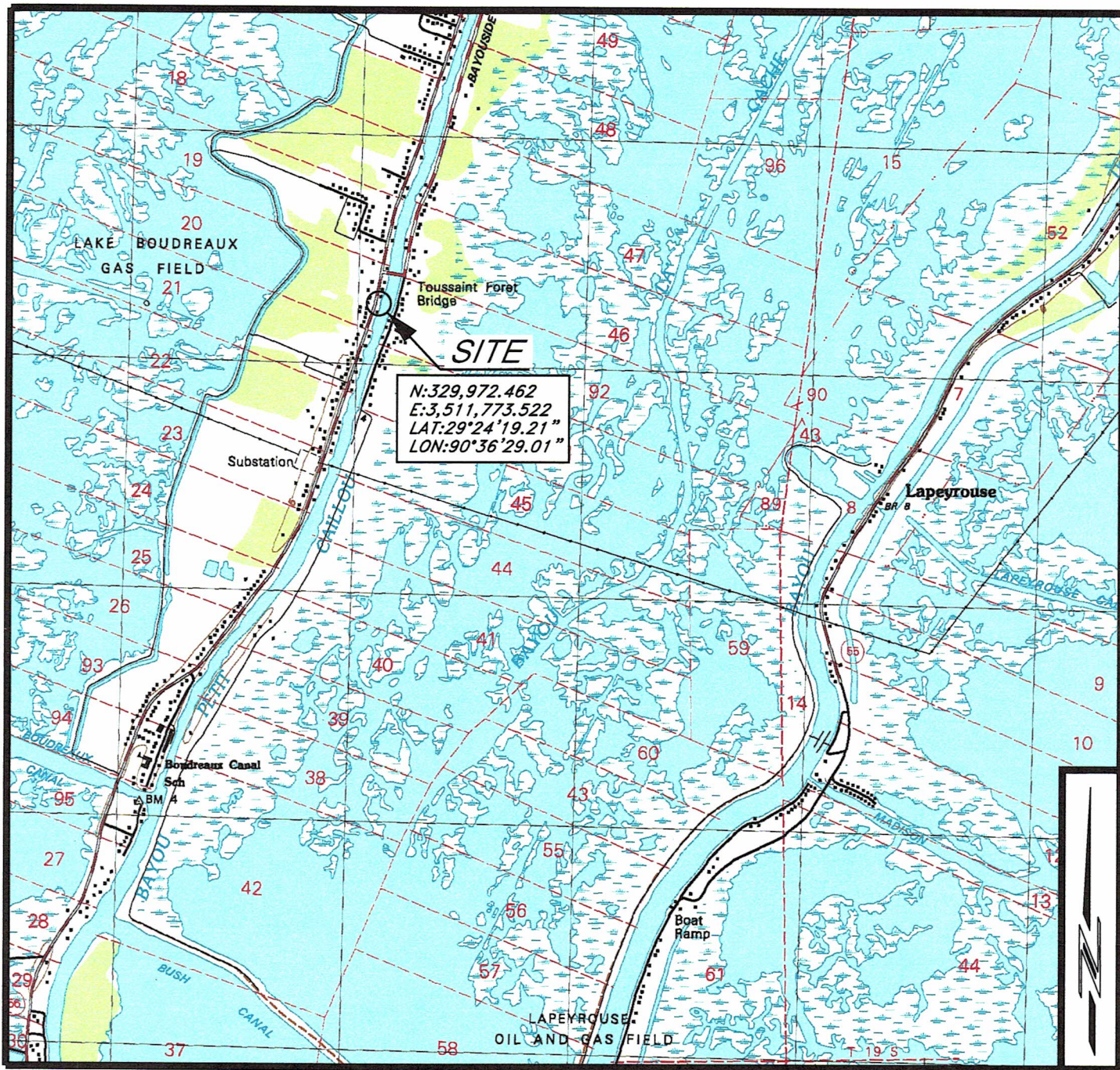

NO.      DATE

REVISION

**"VICINITY MAP"**

**LISA M. TILLMAN**

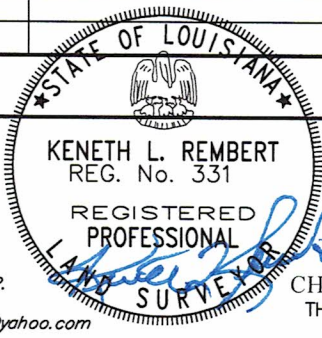

PROPOSED BULKHEAD & SHORELINE REFURBISHMENT  
 LOCATED IN SECTION 20, T19S-R18E  
 CHAUVIN, TERREBONNE PARISH, LOUISIANA  
 THESE PLATS ARE TO BE USED EXCLUSIVELY FOR  
 THE ACQUISITION OF REGULATORY PERMITS.

I CERTIFY THAT THIS SURVEY WAS  
 DONE UNDER MY DIRECT SUPERVISION  
 IN ACCORDANCE WITH THE MINIMUM  
 STANDARDS OF PRACTICE FOR LAND  
 SURVEYORS AND THAT THE ACCURACY  
 STANDARDS ARE IN ACCORDANCE WITH  
 CLASS "D" (RURAL) SURVEYS AS  
 INDICATED IN THE ABOVE STANDARDS.

APPLICATION BY:  
 LISA M. TILLMAN  
 5298 BAYOUSIDE DR.  
 CHAUVIN, LA 70344  
 email: lisamtillman@yahoo.com

**Keneth L. Rembert, PLS**  
 — LAND SURVEYORS —  
 635 SCHOOL STREET, HOUMA, LOUISIANA 70360  
 (985) 879-2782 FAX - (985) 879-1641



GRAPHIC SCALE



N.T.S.

SHEET	1	OF	5
DRAWN BY:	BM		
APPROVED BY:	KLR		
SCALE:	1' = NTS		
DATE:	11 SEP 18		
JOB NUMBER:	18-349		

FILE: LISA-TILLMAN-BULKHEAD-PERMIT-CHAUVIN

**ADJACENT  
PROPERTY OWNERS:**

- ① O'NEIL JOHN SEVIN et ux  
6003 HWY. 56  
CHAUVIN, LA. 70344
- ② PAUL J. SCOTT et ux  
P.O. BOX 191  
CHAUVIN, LA. 70344
- ③ BILLY J. ESCHETE et ux  
88 MILL SITE RD.  
MONTEGUT, LA. 70377
- ④ TRAVIS P. SCOTT  
6006 HWY. 56  
CHAUVIN, LA. 70344

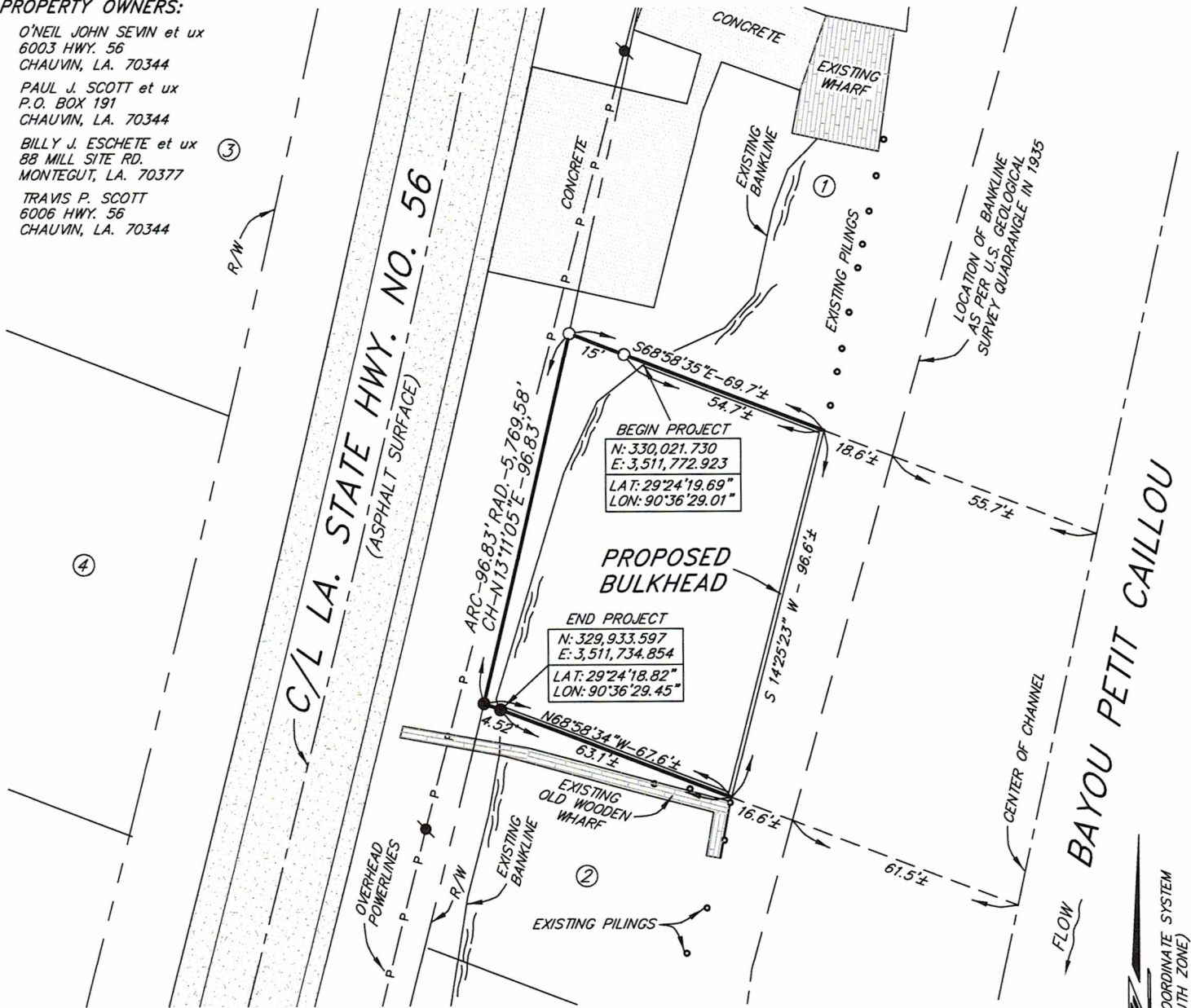

M.H.W. = +1.9'  
M.L.W. = +0.6'

N.A.V.D. '88, NAD 83  
2018 C4G DATUM

**LEGEND:**

- INDICATES 5/8" IRON ROD SET
- INDICATES 5/8" IRON ROD FOUND
- ⦿ EXISTING POWER POLE

NO.	DATE	REVISION



**"OVERALL VIEW"**

**LISA M. TILLMAN**

PROPOSED BULKHEAD &  
SHORELINE REFRUBISHMENT  
LOCATED IN SECTION 20, T19S-R18E  
CHAUVIN, TERREBONNE PARISH, LOUISIANA  
THESE PLATS ARE TO BE USED EXCLUSIVELY FOR  
THE ACQUISITION OF REGULATORY PERMITS.

I CERTIFY THAT THIS SURVEY WAS  
DONE UNDER MY DIRECT SUPERVISION  
IN ACCORDANCE WITH THE MINIMUM  
STANDARDS OF PRACTICE FOR LAND  
SURVEYS AND THAT THE ACCURACY  
STANDARDS ARE IN ACCORDANCE WITH  
CLASS "D" (RURAL) SURVEYS AS  
INDICATED IN THE ABOVE STANDARDS.

APPLICATION BY:  
LISA M. TILLMAN  
5298 BAYOUSIDE DR.  
CHAUVIN, LA 70344  
email: lisamtilman@yahoo.com

**Keneth L. Rembert, PLS**  
— LAND SURVEYORS —  
635 SCHOOL STREET, HOUMA, LOUISIANA 70360  
(985) 879-2782 FAX - (985) 879-1641



SHEET	2	OF	5
DRAWN BY:	BM		
APPROVED BY:	KLR		
SCALE:	1' = 40'		
DATE:	11 SEP 18		
JOB NUMBER:	18-349		

FILE: LISA-TILLMAN-BULKHEAD-PERMIT-CHAUVIN

LOUISIANA COORDINATE SYSTEM  
(SOUTH ZONE)

LA. STATE HWY. NO. 56

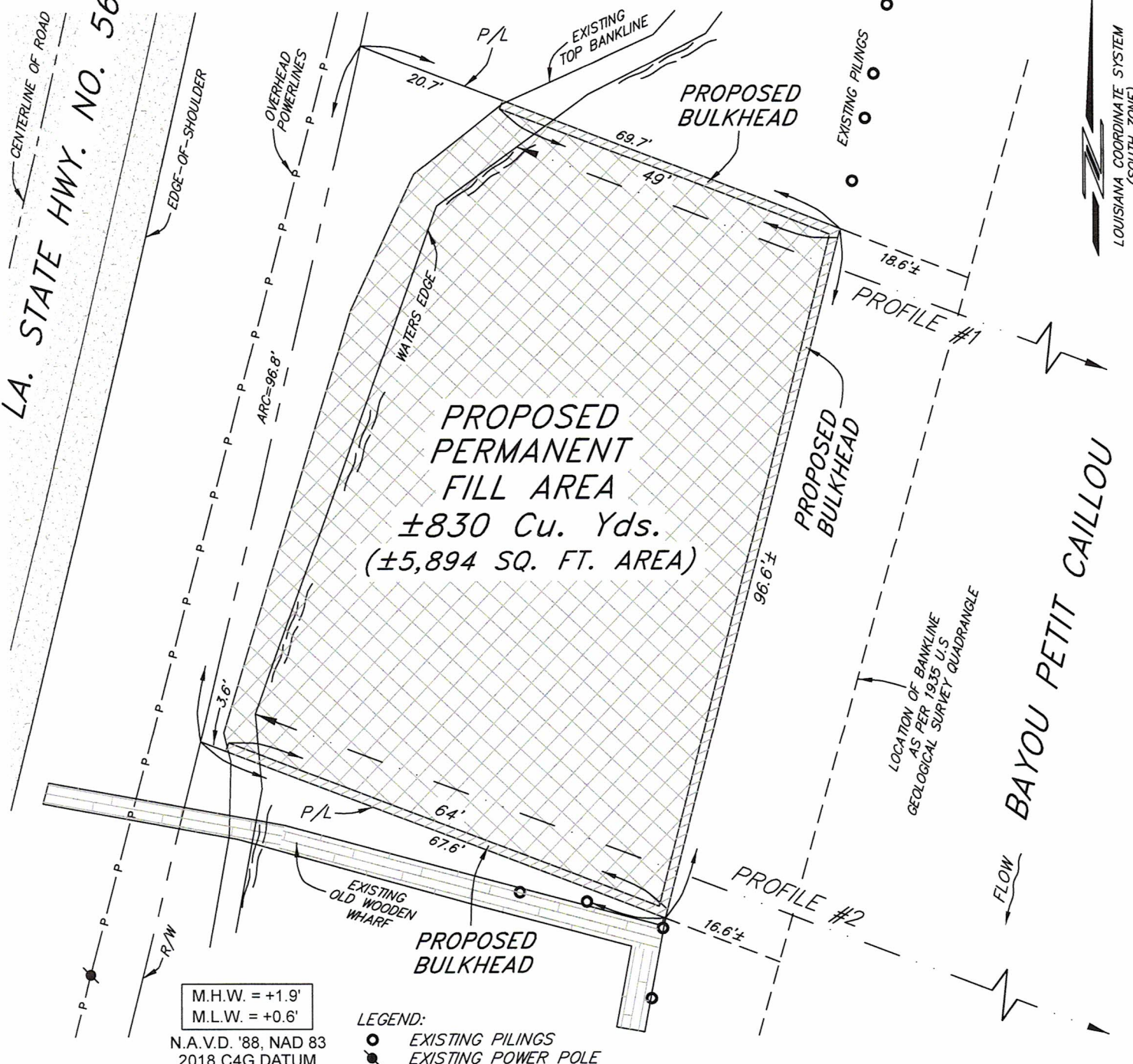

M.H.W. = +1.9'  
M.L.W. = +0.6'

N.A.V.D. '88, NAD 83  
2018 C4G DATUM

LEGEND:  
● EXISTING PILING  
● EXISTING POWER POLE

NO.	DATE	REVISION

"PLAN VIEW"

STATE OF LOUISIANA  
  
**KENETH L. REMBERT**  
 REG. No. 331  
 REGISTERED PROFESSIONAL  
 LAND SURVEYOR

**LISA M. TILLMAN**

PROPOSED BULKHEAD & SHORELINE REFURBISHMENT  
 LOCATED IN SECTION 20, T19S-R18E  
 CHAUVIN, TERREBONNE PARISH, LOUISIANA  
 THESE PLATS ARE TO BE USED EXCLUSIVELY FOR THE ACQUISITION OF REGULATORY PERMITS.

I CERTIFY THAT THIS SURVEY WAS DONE UNDER MY DIRECT SUPERVISION IN ACCORDANCE WITH THE MINIMUM STANDARDS OF PRACTICE FOR LAND SURVEYORS AND THAT THE ACCURACY STANDARDS ARE IN ACCORDANCE WITH CLASS "D" (RURAL) SURVEYS AS INDICATED IN THE ABOVE STANDARDS.

APPLICATION BY:  
**LISA M. TILLMAN**  
 5298 BAYOUSIDE DR.  
 CHAUVIN, LA 70344  
 email: lisamillman@yahoo.com

**Keneth L. Rembert, PLS**  
 LAND SURVEYORS  
 635 SCHOOL STREET, HOUMA, LOUISIANA 70360  
 (985) 879-2782 FAX - (985) 879-1641

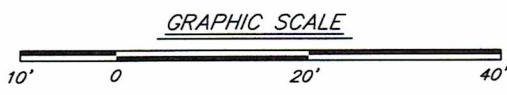

SHEET	3	OF	5
DRAWN BY:	BM		
APPROVED BY:	KLR		
SCALE:	1' = 20'		
DATE:	11 SEP 18		
JOB NUMBER:	18-349		

FILE: LISA-TILLMAN-BULKHEAD-PERMIT-CHAUVIN

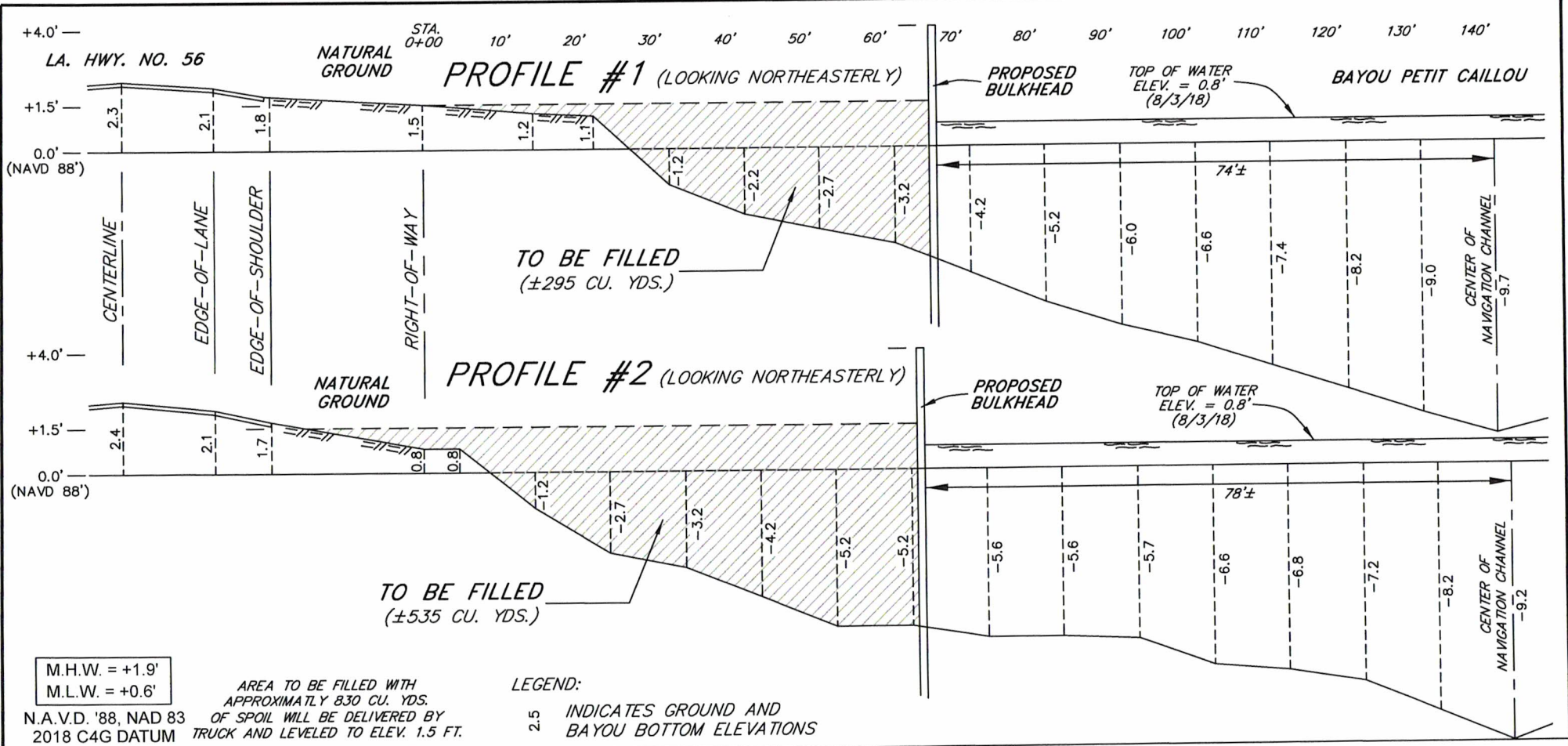

NO.	DATE	REVISION

**"PROFILES"**



APPLICATION BY:  
 LISA M. TILLMAN  
 5298 BAYOUSIDE DR.  
 CHAUVIN, LA 70344  
 email: lisamtillman@yahoo.com

**LISA M. TILLMAN**  
 PROPOSED BULKHEAD &  
 SHORELINE REFURBISHMENT  
 LOCATED IN SECTION 20, T19S-R18E  
 CHAUVIN, TERREBONNE PARISH, LOUISIANA  
 THESE PLATS ARE TO BE USED EXCLUSIVELY FOR  
 THE ACQUISITION OF REGULATORY PERMITS.

I CERTIFY THAT THIS SURVEY WAS DONE UNDER MY DIRECT SUPERVISION IN ACCORDANCE WITH THE MINIMUM STANDARDS OF PRACTICE FOR LAND SURVEYORS AND THAT THE ACCURACY STANDARDS ARE IN ACCORDANCE WITH CLASS "D" (RURAL) SURVEYS AS INDICATED IN THE ABOVE STANDARDS.

**Keneth L. Rembert, PLS**  
 — LAND SURVEYORS —  
 635 SCHOOL STREET, HOUMA, LOUISIANA 70360  
 (985) 879-2782 FAX - (985) 879-1641

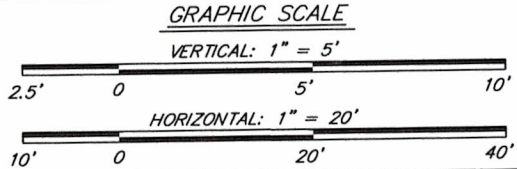

SHEET	4	OF	5
DRAWN BY:	BM		
APPROVED BY:	KLR		
SCALE:	1" = 5' & 1" = 20'		
DATE:	11 SEP 18		
JOB NUMBER:	18-349		

FILE: LISA-TILLMAN-BULKHEAD-PERMIT-CHAUVIN



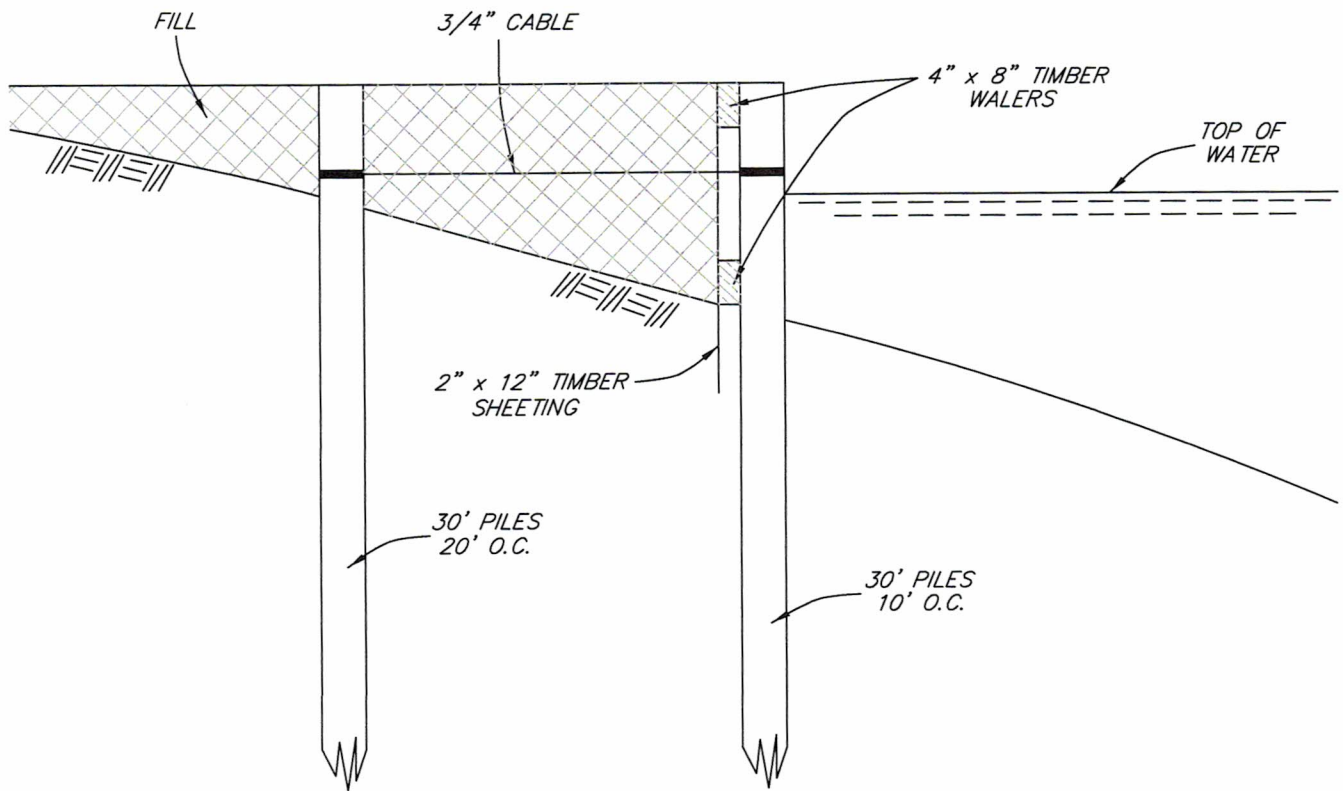

(TYPICAL)

NO.	DATE	REVISION

**"BULKHEAD DETAILS"**



APPLICATION BY:  
 LISA M. TILLMAN  
 5298 BAYOUSIDE DR.  
 CHAUVIN, LA 70344  
 email: lisamillman@yahoo.com

**LISA M. TILLMAN**  
 PROPOSED BULKHEAD &  
 SHORELINE REFURBISHMENT  
 LOCATED IN SECTION 20, T19S-R18E  
 CHAUVIN, TERREBONNE PARISH, LOUISIANA  
 THESE PLATS ARE TO BE USED EXCLUSIVELY FOR  
 THE ACQUISITION OF REGULATORY PERMITS.

I CERTIFY THAT THIS SURVEY WAS  
 DONE UNDER MY DIRECT SUPERVISION  
 IN ACCORDANCE WITH THE MINIMUM  
 STANDARDS OF PRACTICE FOR LAND  
 SURVEYORS AND THAT THE ACCURACY  
 STANDARDS ARE IN ACCORDANCE WITH  
 CLASS "D" (RURAL) SURVEYS AS  
 INDICATED IN THE ABOVE STANDARDS.

**Keneth L. Rembert, PLS**  
 — LAND SURVEYORS —  
 635 SCHOOL STREET, HOUMA, LOUISIANA 70360  
 (985) 879-2782 FAX - (985) 879-1641



GRAPHIC SCALE



N.T.S.

SHEET	5	OF	5
DRAWN BY:	BM		
APPROVED BY:	KLR		
SCALE:	1' = NTS		
DATE:	11 SEP 18		
JOB NUMBER:	18-349		

FILE: LISA-TILLMAN-BULKHEAD-PERMIT-CHAUVIN